

Udini R/C

GLEAM **PRO**

OPERATING INSTRUCTIONS

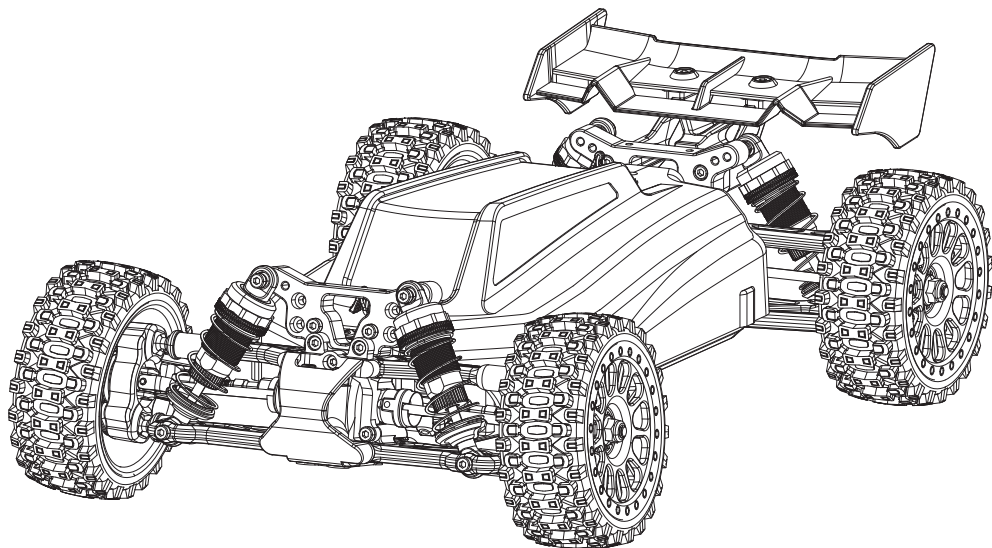

If any problem with the product, **EVEN IF** return period has ended, feel free to reach out to us directly via the retailer which the consumer purchased the product from.

IMPORTANT!
WARRANTY
GUARANTEE

1:12

4x4

2.4
GHZ

14+
AGES

TABLE OF CONTENTS



01

WARNING & PRECAUTION & POLICY STATEMENT 03

	PAGE
01 Important Notice	03
02 Warning Statement	03
03 Use Sequential	04
04 Attention Statement	04
05 Battery Safety Statement	05
06 WEEE Compliance	05
07 FCC Note	06

PAGE

07 VEHICLE SPECIFICATION

07 01 Vehicle data	
07 02 Electronic system spec.	
07 03 Transmission system spec.	
07 04 Structure system spec.	

02

03

QUICK START

	PAGE
Step 1 - Install a spoiler	08
Step 2 - Open the truck body	08
Step 3 - Check the connecting on electronic parts	09
Step 4 - Connect the battery to ESC	09
Step 5 - Install the transmitter batteries	10
Step 6 - Power on transmitter & ESC for frequency pairing	10
Step 7 - Assemble the body & Start to play	11
Step 8 - Power OFF the ESC & transmitter	11
Step 9 - Product maintenance	11

04

ESC, RECEIVER & TRANSMITTER INSTRUCTIONS 12

04-01 ESC instructions	
ESC data	12
ESC installation	12
ESC operation tips	12
ESC Throttle Midpoint Calibration	12

04-02 Receiver instructions	
Receiver data	13
Receiver installation	13

04-03 Transmitter instructions	
Transmitter data	14
Transmitter functions	14
ST.TRIM	15
ST.D/R	15
CH5, Gyroscope adjustment	16
Transmitter indicator light	16
CH4, Speed Limiter Switch	17
Power Switch	17
CH3, Control button	17
CH2, Throttle trigger	18
CH1, Steering wheel	18
Throttle/Steering Center Calibration	18

PAGE

PAGE

19 BUYABLE ACCESSORIES LIST

19 01 Plastic parts & hardware	
20 02 Electronic devices	
21 03 Screw type	
21 04 Tool	

05

PAGE

22 TROUBLE SHOOTING

06

PAGE

45 EXPLOSION VIEW

07



01 - WARNING & PRECAUTION & POLICY STATEMENT

Remark: Including Section 01-01 to 01-07.

01-01

IMPORTANT NOTICE

- (1) The package or instruction manual contains important information and must be **RETAINED**.
- (2) Our company's products are improving all the time, design and specifications are subject to change without notice. All the information in this manual has been carefully checked to ensure accuracy, if any printing errors, our company reserves the final interpretation right.
- (3) The spare parts (including batteries and chargers) mentioned in the User Manual are subject to sales. KIT version not included electronic component. Configurations vary by version, please refer to the sales version.
- (4) Failure to follow these instructions (including PART 01, and others) may result in injury to yourself or others. You may also cause property damage or model damage.
- (5) For more safety precautions, please refer to the "Disclaimer and Safety Operation Guidelines".
- (6) Usage: Please follow the instructions to install and operate the model.



Download the operating guide

01-02

WARNING STATEMENT

Warning:

The product should only be used by adults and children over 14 years. Adult supervision is required for children under 14 years.

Hinweis:

Dieses Produkt ist für die Erwachsene und die Kinder ab 14 Jahren. Die Kinder unter 14 Jahren müssen von Erwachsenen beaufsichtigt werden.

Avertissement:

Ce produit est destiné aux adultes et aux enfants de plus de 14 ans. Les enfants de moins de 14 ans doivent être surveillés par des adultes.

Avvertimento:

Questo prodotto è destinato all'uso per i adulti e bambini di età superiore ai 14 anni. I bambini di età inferiore ai 14 anni devono essere sorvegliati da un adulto.

Advertencia:

Este producto es para adultos y niños mayores de 14 años. Los niños menores de 14 años deben ser supervisados por adultos.

警告: この製品は、大人と14歳以上の子供には使用対象です。

14歳未満の子供は大人の監視が必要です。

. ويحتاج الأطفال دون سن الرابعة عشره إلى رعاية البالغين

تحذير : هذا المنتج يستخدم فقط من قبل البالغين والأطفال فوق سن 14



DANGER!
Only suitable
for age 14+

Before Operation	<ol style="list-style-type: none"> (1) Read the instruction manual in detail, or ask for the person with experience in operation, and read with the guardian if necessary. (2) Make sure all screws and nuts are properly tightened. (3) The transmitter and the vehicle should always use the battery with saturated power to avoid losing control of the model. (4) Please make sure that the throttle trigger is in the center position.
During Operation	<ol style="list-style-type: none"> (1) First turn on the power of the transmitter, and then turn on the power of the model. (2) Use this product only in open areas (>5x5m) without pedestrians. (3) DO NOT put fingers or any objects inside rotating and moving parts.
After Operation	<ol style="list-style-type: none"> (1) First turn off the model power, then turn off the transmitter's power, and take out the all battery. (2) Daily maintenance is required after the model is used.

- (1) The model must stop immediately and check for the reasons when it is operating abnormal.
- (2) Keep in mind that people around you may also operate a radio control model.
- (3) The motor is a heating part, please do not touch it.
- (4) If you don't use the model for a long time, please raise the chassis to let the wheels hang in the air.
- (5) Please use this product only in empty place! It is strictly forbidden to use it on roads, living area, parks, indoor areas, children or places where people gather, otherwise injury may occur.



The product contains small and sharp parts. Keep away from children.



Be sure to read the instruction manual in detail, or ask for the person with experience in operation, and read with the guardian if necessary.

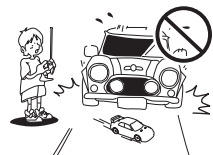

DO NOT operate in public streets or crowded places to avoid accidents.



Cutters, nippers and screw drivers need careful handling.

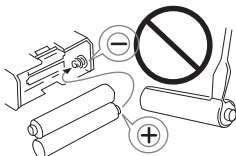

Please don't reverse contact or disassemble the battery, as this way will cause the battery to explode.

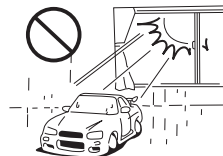

DO NOT put the model in high temperature, humidity and direct sunlight.

- Please read and observe all precautions before use. Improper use of battery may cause danger.
 - It is normal for the battery to heat up after operation. Please be careful when handling the battery. If the wire is worn, it is easy to short circuit and cause fire.
- 1) Pay attention to the polarity of the battery when installing or replacing the battery;
 - 2) Different types of batteries or old and new batteries should not be mixed;
 - 3) After use, please disconnect the power supply and pull out the plug;
 - 4) DO NOT charge the battery when it is bulging or expanding;
 - 5) Keep away from damp, corrosive environment and heat source;
 - 6) DO NOT short circuit, decompose or put the battery into fire;
 - 7) Please use the attached special charger to charge the battery;
 - 8) Please charge the battery under adult supervision;
 - 9) Remove the battery from the model before charging;
 - 10) DO NOT short circuit any terminals.



**▲ WARNING
FIRE HAZARD!**



Li-Po Battery Disposal & Recycling

Wasted Lithium-Polymer batteries must not be placed with household trash. Please contact local environmental or waste agency or the supplier of your model or your nearest Li-Po battery recycling center.



Please help the environment by disposing of your product responsibly at the end of its life. The wheeled bin symbol indicates that this product should not be disposed of in your household waste containers. Instead, the product should be disposed of by using a designated collection point for the recycling of waste electrical and electronic equipment. The Waste of Electrical and Electronic Equipment (WEEE) Directive (2002/96/EC) requires that the best available recycling techniques be employed to minimize the impact on the environment.

Recycling electronics helps by keeping harmful chemicals out of the environment, and also saves money by reusing precious metals. Remove any batteries and dispose of them and the product at your local authority's recycling facility. For more information about where you can drop off your waste equipment for recycling, please contact your local city office your household waste disposal service, or the location where you purchased this product.



This equipment has been tested and found to comply with the limits for a Class B digital device, pursuant to Part 15 of the FCC Rules. These limits are designed to provide reasonable protection against harmful interference in a residential installation. This equipment generates uses and can radiate radio frequency energy and, if not installed and used in accordance with the instructions, may cause harmful interference to radio communications. However, there is no guarantee that interference will not occur in a particular installation. If this equipment does cause harmful interference to radio or television reception, which can be determined by turning the equipment off and on, the user is encouraged to try to correct the interference by one or more of the following measures:

- Reorient or relocate the receiving antenna.
- Increase the separation between the equipment and receiver.
- Connect the equipment into an outlet on a circuit different from that to which the receiver is connected.

WARNING: Changes or modifications not expressly approved by the party responsible for compliance could void the user's authority to operate the equipment.

FCC Notice

The equipment may generate or use radio frequency energy. Changes or modifications to this equipment may cause harmful interference unless the modifications are expressly approved in the instruction manual. Modifications not authorized by the manufacturer may void user's authority to operate this device.

This device complies with Part 15 of the FCC Rules. Operation is subject to the following two conditions: (1) this device may not cause harmful interference, and (2) this device must accept any interference received, including interference that may cause undesired operation.

FCC Radiation Exposure Statement

The device has been evaluated to meet general RF exposure requirement.

The device can be used in portable exposure condition without restriction.



WARNING:

CHOKING HAZARD - Small parts. Not for children under 3 yrs.

Erstickende Gefahr - Kleine Teile. Nicht für Kinder unter 3 Jahren.

Danger d'étouffement - petites pièces. Pas pour les enfants de moins de 3 ans.

Peligro de asfixia - Pequeñas piezas. No para niños menores de 3 años.

مخاطر الخنق - اجزاء صغيرة. ليس للأطفال تحت 3 سنوات.





02 - VEHICLE SPECIFICATION

Remark: Including Section 02-01 to 02-04.

02-01 VEHICLE DATA

Model No.	UD1204PRO
Vehicle Scale	1:12
Vehicle Size	L344×W202×H97mm
Vehicle Weight	1131g (without battery)
Wheelbase	228mm
Ground Clearance	25mm
Battery Compartment Size	L115×W38×H25mm
Wheel Size	∅73.5×29mm

02-02 ELECTONIC SYSTEM SPEC.

Motor	2845-4700KV Brushless Motor
ESC	Electronic Speed control(ESC), refer to "Section 04-01".
Receiver	Refer to "Section 04-02".
Steering Servo	3 wires, 17g copper gear digital servo
Transmitter	Refer to "Section 04-03" for detail.

02-03 TRANSMISSION SYSTEM SPEC.

Pinion Gear	0.8M 10T Metal (Position: assembled on the Motor Shaft)
Spur Gear	0.8M Metal (Position: assembled on the center differential)
Input Gear	1M 10T Metal (Position: assembled on the Main Shaft)
Main Differential Gear	1M 30T Metal
Satellite Gear	0.8M 16T Metal
Planetary Gears	0.8M 8T Metal
Main Driveshaft	Metal
Universal Driveshaft	Metal

02-04 STRUCTURE SYSTEM SPEC.

Truck Body	PC
Chassis	2.0mm Thickness High-quality Nylon
Suspension Arm	High-quality Nylon
Shock Absorber	Oil-filled Shock Absorber, Metal
Shock Tower	Metal
Wheel Hex	Metal
Deck Board	2.0mm Thickness High-quality Nylon
Motor Mount	Metal



03 - QUICK START

Remark: Including Section 03-01 to 03-09.

03-01 STEP 1 - INSTALL A SPOILER

Remove the spoiler (P12-122) from the accessory pack and install it onto the vehicle as shown in the illustration.

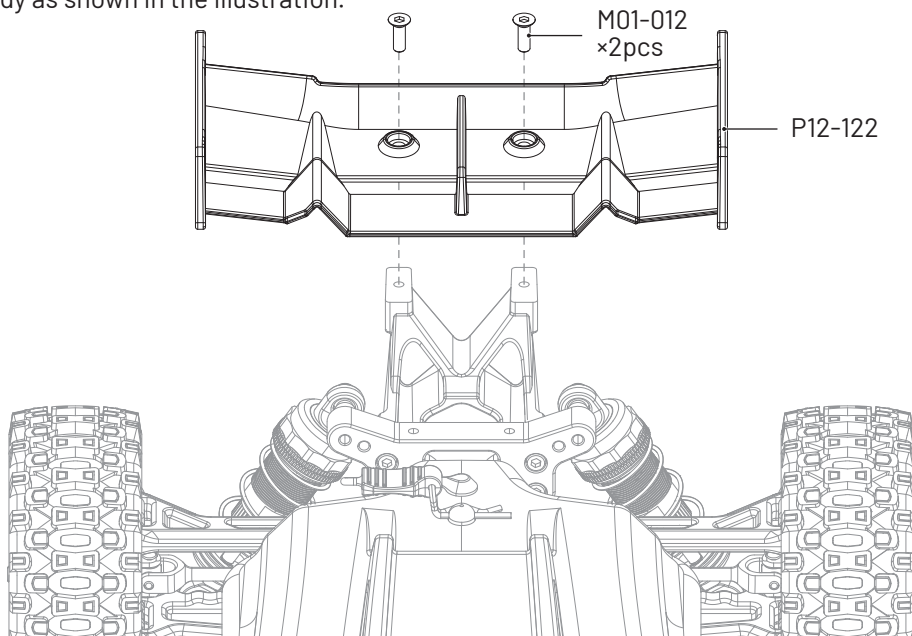

03-02 STEP 2 - OPEN THE TRUCK BODY

Step 2-1: Pull out the front and rear clip (RLL01).

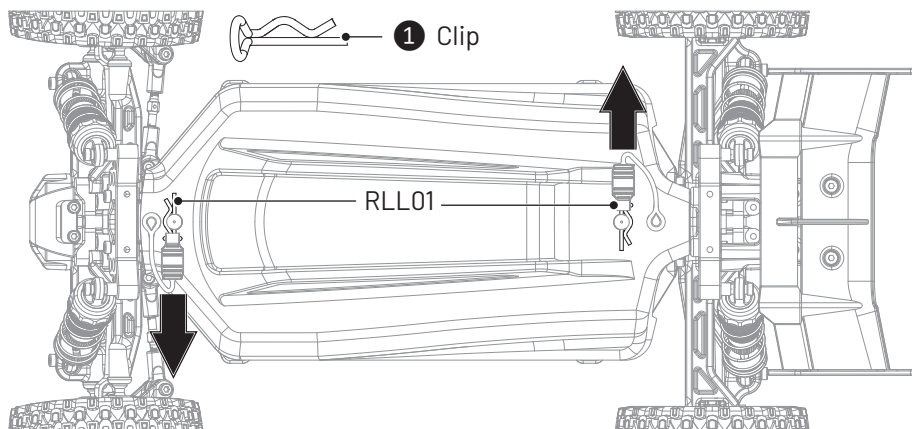

Step 2-2: Lift the body shell(P12-121A) upward and remove it.

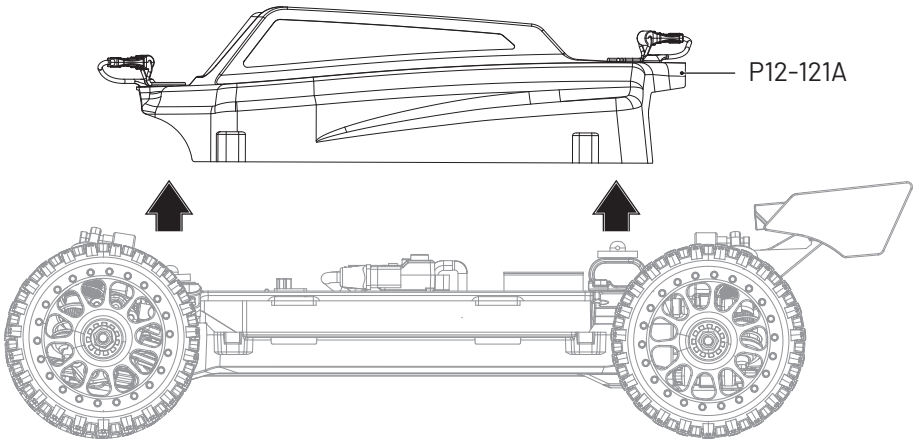

03-03 STEP 3 - CHECK THE CONNECTING ON ELECTRONIC PARTS

● After removing the truck body, check the connecting among ESC and other electric parts per the instruction of "Section 04-01-03".

03-04 STEP 4 - CONNECT THE BATTERY TO ESC

● Put the battery into the battery compartment, fix the battery with Velcro and then connect with the ESC. Take out the battery when not in use, otherwise the battery is easily damaged.

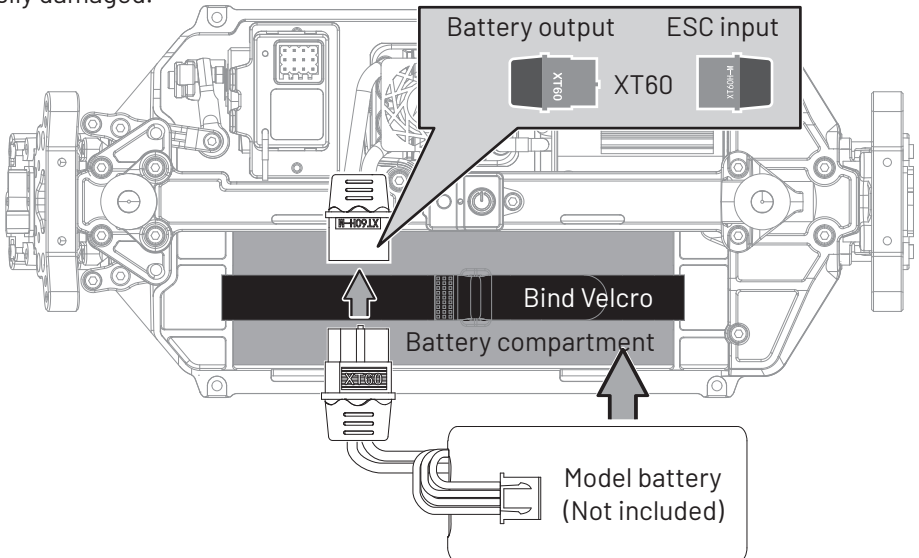

Open battery cover at the bottom of transmitter. Install batteries. Follow the direction of batteries designated in the inside of the battery box.

OPEN THE BATTERY COVER

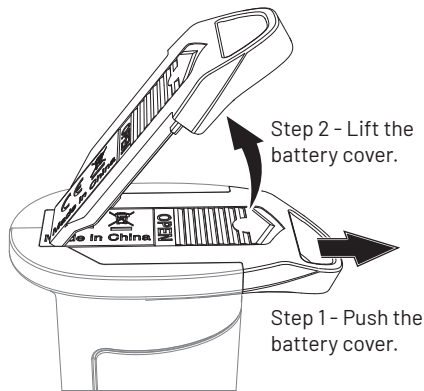

Input Power Method 2

- Step 1: Remove the 1.5V AA battery case.
- Step 2: Put the 7.4V Li-battery with connector type XH2.54-3pin inside the battery compartment.
- Battery compartment capacity: 70×37×19mm

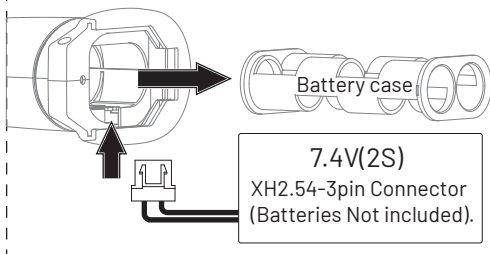

NOTE POLARITY DIRECTION

Input Power Method 1

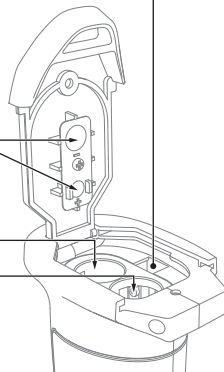
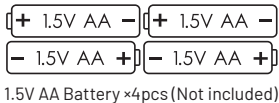

1

Always power on your transmitter first

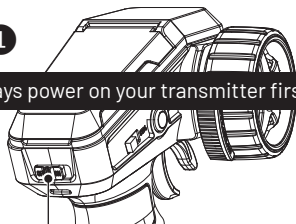

Toggle Switch

OFF OFF ON ON

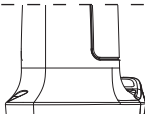

- 1) Always turn on the transmitter power first, then turn on the ESC power.
- 2) The devices will automatically pair. All lights staying steadily on indicates successful pairing. Otherwise, pairing has failed and must be repeated. Refer to Section 04-03-09 (Function 1).

2

And then power on the ESC

Press the power button

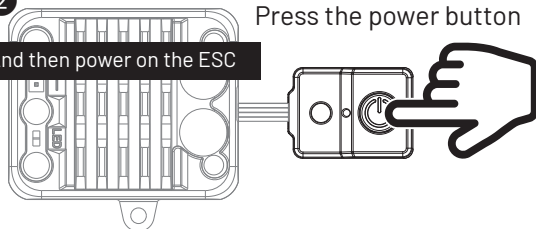

03-07 STEP 7 - ASSEMBLE THE BODY & START TO PLAY

Installation of the body shell(P12-121A) follows the reverse procedure of removal. Reinstall the body to its original position and reinsert the clip(RLL01).

Placed on Horizontal ground

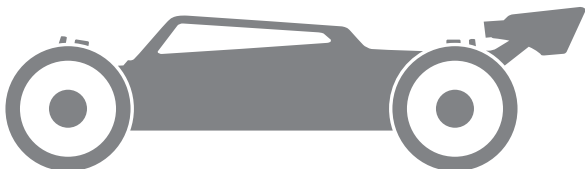

03-08 STEP 8 - POWER OFF THE ESC & TRANSMITTER

- (1) First, turn off the vehicle's ESC (press and hold ≤ 2 second) power and remove the battery. Open the truck body and refer to "Section 03-02" for details.
- (2) Second, turn off the transmitter power and remove the battery. Open the battery cover and refer to "Section 03-05" for details.
- (3) IMPORTANT: Always power OFF the ESC before the transmitter.

03-09 STEP 09 - PRODUCT MAINTENANCE

When not in use, remove the battery from the model and transmitter.

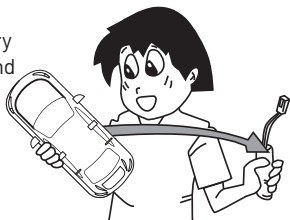

Please remove the sediment and dirt on the car completely and must be kept dry after play.



Apply lubricating oil to external metal parts.



Please separate the car and battery when not in use.

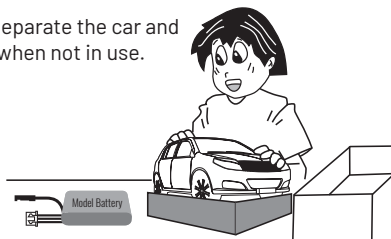



04 - ESC, RECEIVER & TRANSMITTER INSTRUCTIONS

Remark: Including Section 04-01 to 04-03.

04-01 ESC INSTRUCTIONS

04-01-01 ESC DATA

Model:	ESC60
RF Standard	2.4GHz
Input Power	2-3S (7.4V-11.1V)
Rated current	60A
Size	39.7×21×33mm
Power Connector	XT60
Motor Limit	2-3S, LiPo
Motor Connector	3.5mm banana connector

04-01-02 OPERATION TIPS



- 1) When starting to use the RC car, always turn on the transmitter power before turning on the ESC power.
- 2) After using the RC car, always turn off the ESC before turning off the transmitter power.

04-01-03 ESC INSTALLATION

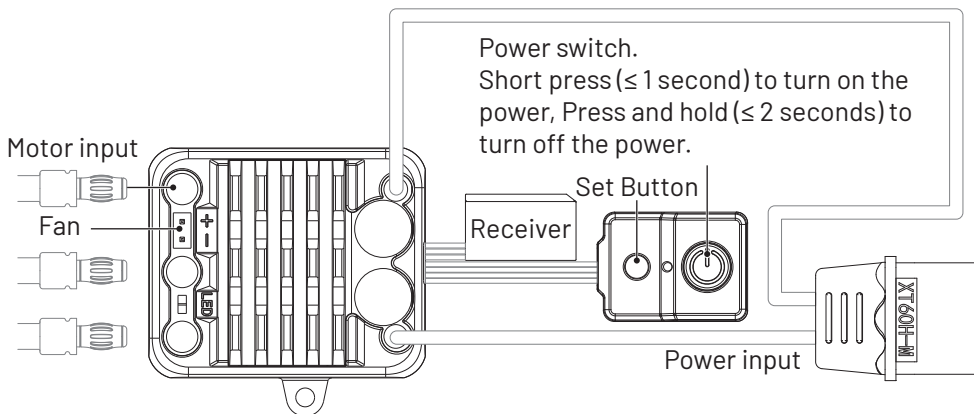

04-01-04 ESC THROTTLE MIDPOINT CALIBRATION

- 1) Turn on the transmitter power.
- 2) Move the throttle limit switch (CH4) to the highest speed position (100%).
- 3) Press and hold the Set button, then turn on the ESC power. Release the Set button after hearing a "D" tone.
- 4) Pull the throttle trigger back to its full range (maximum position). Release it after hearing a "D" tone.
- 5) Push the throttle trigger forward to its full range (maximum position). Release it after hearing "DD" tones (two beeps).
- 6) After hearing "DDD" tones (three beeps), press the Set button once to save the settings. Calibration is finished.
- 7) Turn off the ESC power.

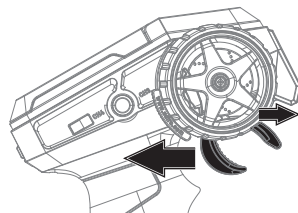

Note: Refer to section 04-03-02 for details about the transmitter.

04-02 RECEIVER INSTRUCTIONS

04-02-01 RECEIVER DATA

Model	SR6
RF Standard	2.4GHz
Input Voltage	3.6-12V
Rated current	5A
Size	32×15×20mm

04-02-02 RECEIVER INSTALLATION

Gyroscope Reverse Switch Button

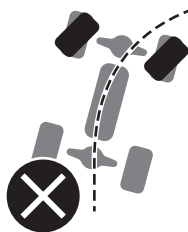

Gyroscope
same-direction
action

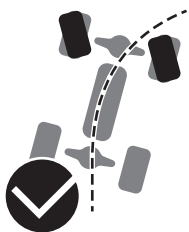

Gyroscope
reverse-direction
action

When the gyroscope's action is opposite, this button can be used to switch. (Use a slender tool like a pin to press into this hole.)

- ① Press the button: one flash indicates positive;
- ② Press the button: two flashes indicate negative.

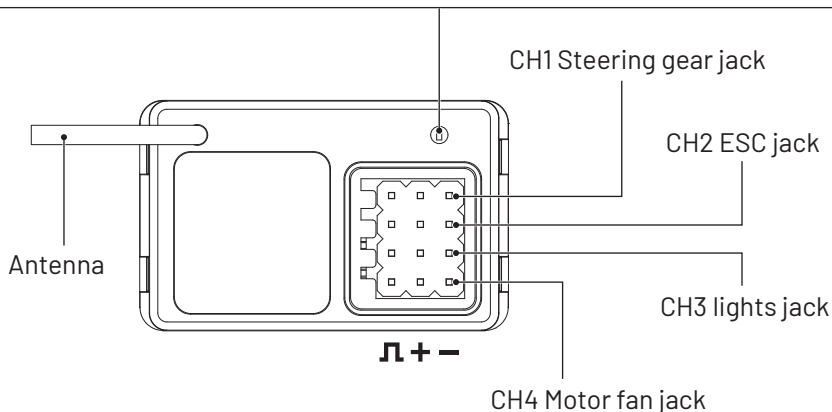

04-03 TRANSMITTER INSTRUCTIONS

Before installing and operating your transmitter, please take a few minutes to familiarize yourself with the various features of the system by reading this instruction manual thoroughly.

04-03-01

TRANSMITTER DATA

Model	UA42-E01
Control Type	Proportional
Frequency Band	2.4GHz
Channels	4
Control Distance	100m
Input Power Method 1	1.5V AA Battery × 4pcs
Input Power Method 2	7.4V Battery with connector type XH2.54-3pin

04-03-02

TRANSMITTER FUNCTIONS

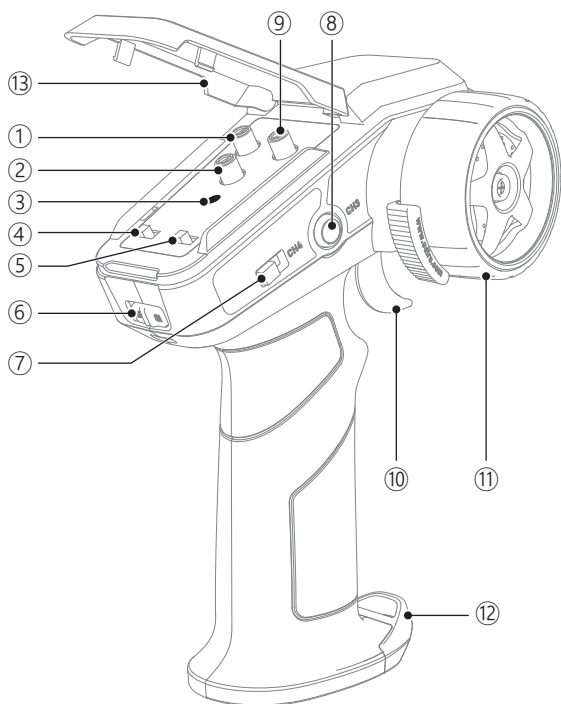

① ST. TRIM
Steering Trim,
refer to "Section 04-03-03".

② CH5
Gyroscope action ratio adjustment,
refer to "Section 04-03-05".

③ Transmitter Indicator
Refer to "Section 04-03-06".

④ TH. REV
Reverse the throttle function.

⑤ ST. REV
Reverse the steering function.

⑥ Power Switch
Power on / off the transmitter,
refer to "Section 04-03-08".

⑦ CH4
Throttle Speed Limiter Switch, refer
to "Section 04-03-07" for detail.

⑧ CH3 Control Button
Refer to "Section 04-03-09".

⑨ ST. D/R
Steering Dual Rate,
refer to "Section 04-03-04".

⑩ CH2, Throttle Trigger
Control the vehicle to move forward/backward,
refer to "Section 04-03-10".

⑪ CH1, Steering Wheel
Control the vehicle to turn right/left,
refer to "Section 04-03-11".

⑫ Battery Cover
Battery installation, refer to "Section 03-05".

Steering Trim: Trim adjustment allows you to finely tune the inputs from your transmitter. It's the dial you reach for when your RC car isn't tracking straight. The steering trim is what helps navigate the RC car in a straight line.

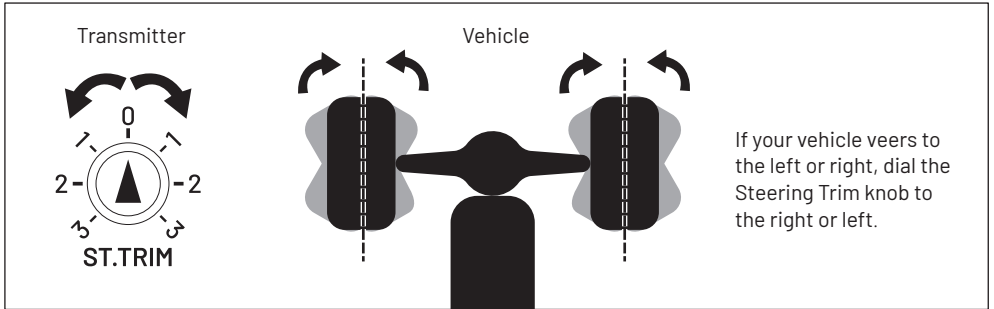

Steering Dual Rate: Steering Dual Rate knob can be set to control the steering throw:
 (1) Turning the knob clockwise to increase the steering throw.
 (2) Turning the knob anticlockwise to reduce the steering throw.

Sample 1

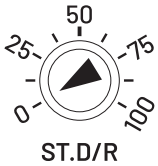

Step 1- Set the ST.D/R knob to "0" position.
 Step 2- Dial the steering wheel of transmitter to the end.

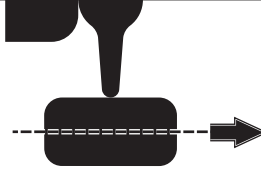

Result: The wheels cannot turn right or left, only can run straight, even you dial the steering wheel to the end.

Sample 2

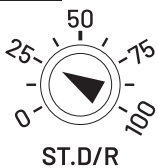

Step 1- Set the ST.D/R knob to "25" position.
 Step 2- Dial the steering wheel of transmitter to the end.



Result: The wheels can turn right or left under 25% steering throw, turn wider than 0%(Sample 1).

Sample 3

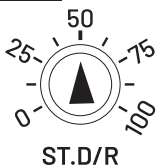

Step 1- Set the ST.D/R knob to "50" position.
 Step 2- Dial the steering wheel of transmitter to the end.



Result: The wheels can turn right or left under 50% steering throw, turn wider than 25%(Sample 2) and 0%(Sample 1).

Note: Above are the samples to help the players to under the ST. D/R function.

The vehicle gyroscope detects motion states based on the conservation of angular momentum, real-time monitoring of Body attitude, Rotational angular velocity, Correcting vehicle posture and direction dynamically. Use the CH5 knob on the Transmitter to adjust the gyroscope's effect ratio and sensitivity:

- (1) Clockwise rotation: Increases the effect ratio (enhances gyroscopic correction force).
- (2) Counterclockwise rotation: Decreases the effect ratio (reduces gyroscopic intervention).

1. Before using the ratio of gyroscope on the transmitter, adjust the Steering Trim so that the vehicle can drive as straight as possible, then turn on the gyro. (If the vehicle's inherent steering neutral point is off-center, turning on the gyro will cause it to constantly work in a correction state during driving, resulting in the vehicle wobbling/swerving left and right continuously.)

2. If the gyro sensitivity is set too high, resulting in excessive correction responsiveness, the vehicle will wobble or oscillate left and right during high-speed runs. In this case, appropriately reduce the gyro sensitivity until the vehicle no longer shakes or wobbles at high speed.

3. The higher the gyro sensitivity, the greater its intervention in steering (resulting in a larger turning radius).

Sample 1

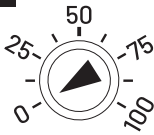

When the CH5 knob is set to "0", the gyroscope's effect ratio is completely disabled.

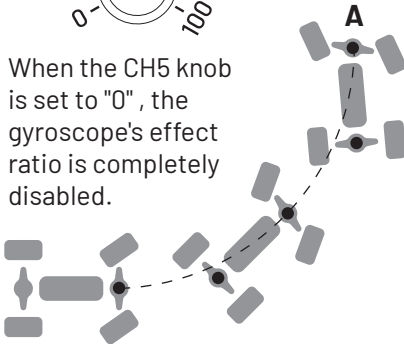

Sample 2

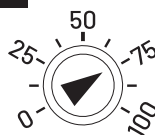

When the CH5 knob is set to "75", the gyroscope's effect ratio is increased

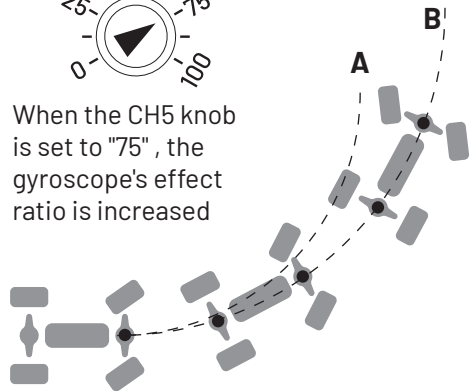

Note: The examples above are provided solely to help players understand the function of adjusting the gyroscope's effect ratio.

Indicator light

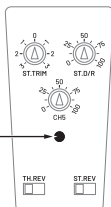

Situation 1: When the signal is weak or interrupted, the indicator will flash quickly.

Situation 2: When the power of the transmitter is low, the indicator light will flash slowly.

The above situation should be handled as soon as possible to avoid accidents.

Throttle Speed Limiter has 3 speed levels: 50%, 75%, 100%.

50% Speed Level is the training mode; recommend the new beginner to play under 50% Speed Level first.

50

75

100



Low speed:50%



Medium speed:75%



High speed:100%

OFF  ON

Please make sure the transmitter throttle trigger and Steering wheel are normal before starting up. Do not touch the throttle trigger & steering wheel when turning on the power of the transmitter.

After powering on, the transmitter will automatically pair with the device, and the indicator light will remain steadily lit. If the indicator light blinks, please refer to "Section 04-03-09" for troubleshooting instructions.

Function 1: Frequency Paring

If automatic pairing fails, turn off all power sources. ① Restart the ESC power supply. ② Press and hold the CH3 button while turning on the transmitter power. ③ Release CH3. When all lights stay lit continuously, pairing is successful.

Function 2: Turn vehicle lights off/on

CH3 lights jack on the control receiver (SR6).

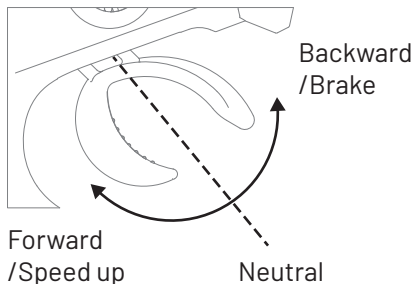
**Note:**

When using the transmitter in electric powered vehicles, the throttle trigger should always remain in the neutral position. Otherwise the vehicle may suffer erratic operation of the throttle trigger functions.

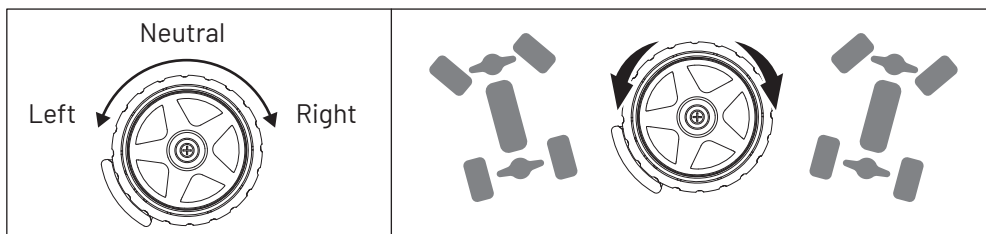

- 1) Turn off both the vehicle and the transmitter.
- 2) Push the throttle trigger and steering wheel to their full range.
- 3) Turn on the transmitter power, then release the throttle trigger and steering wheel.
- 4) Turn the steering wheel to the left/right full range multiple times.
- 5) Pull the throttle trigger forward/backward to the full range multiple times.
- 6) Press the CH3 button once to save. Calibration is now complete.
- 7) Turn off the transmitter power.

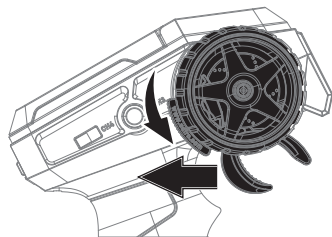



05 - BUYABLE ACCESSORIES LIST

Remark: Including Section 05-01 to 05-04.

05-01 PLASTIC PARTS & HARDWARE

Part#	Name
P12-121A	Body assembly (Pink)
P12-121D	Body assembly (Transparent)
P12-122	Spoiler
P12-123	Bumper assembly (Front)
P12-124	Bumper assembly (Rear)
P12-125	Body pillar
P12-126	Wheel
P12-127	Tire Casing
P12-104	Chassis
P12-105	Upper chassis
P12-107	Suspension arms (Front)
P12-108	Suspension arms (Rear)
P12-109	Front & Rear wheel carriers
P12-114B	Center differential main spur gear (0.8m, 38T, Steel)
P12-115B	Drive bevel gear (10T, Steel)
P12-116C	Center Differential (Steel)
P12-117	Motor mounts (Zinc alloy)
P12-118	Main driveshaft (H4×172.4mm)
P12-129A	Vehicle decals
P16-017A	Servo mounts
P16-004B	Wheel adapters (Metal)
P16-006B	Steering linkage (Adjustable)
P16-007B	Universal drive shaft (Metal)
P16-009C	Shock absorber (Metal)
P16-015	Servo arm set
P16-016	Steering mechanism
P16-019D	Drive bevel gear (10T, Steel)
P16-022C	Pinion gear (ø3.175mm, 0.8m, Steel)
P16-023E	Differential assembly (Steel)
P16-049	Butterfly rack (Metal)
P16-025	Differential housing
P16-029B	Differential cup (Metal)
P16-030B	Sun gear (Powder Metallurgy)
P16-031D	Differential large bevel gear (30T, Steel)

05-01**PLASTIC PARTS & HARDWARE****Part#****Name**

P16-032B	Planetary gear (Powder Metallurgy)
P16-033	Bind Velcro
P16-036	Motor heat sink
P16-064B	Differential Case (Aluminum alloy)
RLL01	Clip

05-02**ELECTRONIC DEVICES****Part#****Name**

S1703	Steering sevro (Metal gear)
ESC60	60A, Electronic Speed control (ESC)
SR6	Receiver
UA42-E01	Transmitter
BL2845-47	Brushed motor (2845-4700KV)
FUN16-2510	Cooling fans (25×25×10mm)
FUN16-3007	Cooling fans (30×30×7mm)
USB-CH1111500	USB Charger (For 11.1V)
B3001	B3 Charger (For 7.4-11.1V)
ESC-ST001	Programming Card
MB-XT2411	XT60 Model battery (11.1V, 2400mAh)

05-03 **SCREW TYPE**

Part#	Name
M01-003	Hexagon socket head cap tapping screw (ø2.6×10mm HB)
M01-004	Hexagon socket head cap tapping screw (ø2.6×12mm HB)
M01-005	Hexagon socket head cap tapping screw (ø2.6×15mm HB)
M01-006	Hexagon socket head cap tapping screw (ø2.6×20mm HB)
M01-010	Hexagon socket head cap machine screw (ø3×8mm HM)
M01-012	Hexagon socket countersunk head tapping screw (ø2.6×8mm KB)
M01-016	Hexagonal flat round head self tapping screw (ø2.6×6mm TB)
M01-017	Hexagonal flat round head self tapping screw (ø2.6×8mm TB)
M01-020	Hexagon socket button head machine screw (2.5×15mm TM)
M01-021	Hexagon socket button head machine screw (3×12mm TM)
M01-031	Set screw (ø4×3mm)
M01-033	Hexagon socket button head machine screw (2.5×18mm TM)
M01-052	Hexagonal cup head half tooth self tapping screw (ø2.5×13.5)
M01-053	Hexagonal cup head half tooth self tapping screw (ø2.5×20.5)
M01-058	Hexagon socket countersunkhead tapping screw (2.0×8mm KM)
M01-059	Ball Head Screw (ø8.2×24.76mm)
M01-063	Hexagon socket countersunkhead tapping screw (2.0×6mm KM)
M02-003.01	M4 hex flanged lock nut
M03-007	Ball bearing (ø6.35×ø9.5×3.2mm)
M03-012	Ball bearing (ø8×ø12.7×4mm)
M04-006	Washer (M4×7×0.8)
M04-007	Washer (M8×10×0.5)
M05-041	Hollow ball (ø5×5.6mm)
M05-043	Hollow ball (ø5×9.9mm)
M06-014	Pin (ø1.95×9.5mm)
M06-015	Pin (ø2.5×27mm)
M06-016	Pin (ø2.5×38mm)
1601-022	Pin (ø1.8×6.8mm)

05-04 **TOOL**

Part#	Name
HS-RTW01	Screwdriver set (H1.27/1.5/2.0/2.5/3.0, C-HS-M4)



06 - TROUBLESHOOTING

PROBLEM		POSSIBLE REASON	SOLUTION
Vehicle Not Running	Model battery low or damaged.		Install Fully Charged Battery.
	ESC wires or motor worn or broken.		Check Status, Reconnect and Insulate.
	ESC overheating triggers high-temperature protection.		Stop Driving, ESC or Motor Must Cool.
	Motor damaged.		Replace New Unit.
	ESC or receiver damaged.		Replace New Unit.
	Wheels or drive shaft entangled with debris.		Check Components, Clear Debris.
	Vehicle out of control range.		Operate Vehicle Within Transmitter Control Range.
Short Run Time, Poor Performance	Battery damaged or not fully charged.		Check Status, Replace or Charge.
	Motor dirty or damaged.		Clean, Check Condition or Replace.
	Terrain resistance causes excessive power consumption.		Play on Other Terrain.
	Drive system dirty or damaged.		Clean, Check Condition or Replace.
Limited Steering Angle	Steering travel rate on transmitter set incorrectly.		Adjust steering travel rate, refer to section 04-03-04.
	Steering components damaged.		Check components and replace.
	Transmitter steering wheel not centered.		Calibrate steering wheel, refer to section 04-03-12.
Transmitter Indicator Not Lit, or Unable to Control Vehicle	Transmitter battery low or installed incorrectly.		Replace new battery, refer to section 03-05.
	Receiver wire loose or connected incorrectly.		Reconnect signal wire on ESC to receiver.
	Transmitter and receiver paired incorrectly.		Re-pair, refer to section 04-03-09.
	Transmitter damaged.		Replace new unit.
Steering/Throttle Intermittent Operation	ESC overheating causes shutdown.		Stop driving, ESC or motor must cool.
	Transmitter and receiver paired incorrectly.		Check for interference sources, or re-pair.
Vehicle Moves Left/Right Unsteadily	Servo not set correctly.		Adjust servo setup.
	Steering components damaged.		Check and replace components.
	Drive system dirty or damaged.		Clean, check or replace.
Steering/Throttle Operation Reversed	"TH.REV" or "ST.REV" set opposite on transmitter.		Adjust "TH.REV" or "ST.REV".
	Check ESC-to-motor wire connections are correct.		Disconnect and reconnect.
Speed Lower Than Nominal	Lower speed selected on throttle limit switch.		Select higher speed on throttle limit switch.
	Pinion gear stuck on motor mount.		Remove motor mount to adjust pinion gear.
Long Frequency Matching Time		Signal interference.	Restart vehicle and transmitter.
Operation Delay		Possible obstacles or interference.	Remove or avoid obstacles or interference.
Vehicle Automatically Moves Forward (Backward) or Makes "en..." Sound		Transmitter issue.	Restart transmitter, or adjust throttle neutral position, refer to section 04-03-12.



07 - EXPLOSION VIEW

Remark: Including Section 07-01 to 07-08.

Refer to Page 45 for detail.



07 - EXPLOSION VIEW

Remark: Including Section 07-01 to 07-08.

07-01

FRONT ASSEMBLY (The left and right installation is the same)

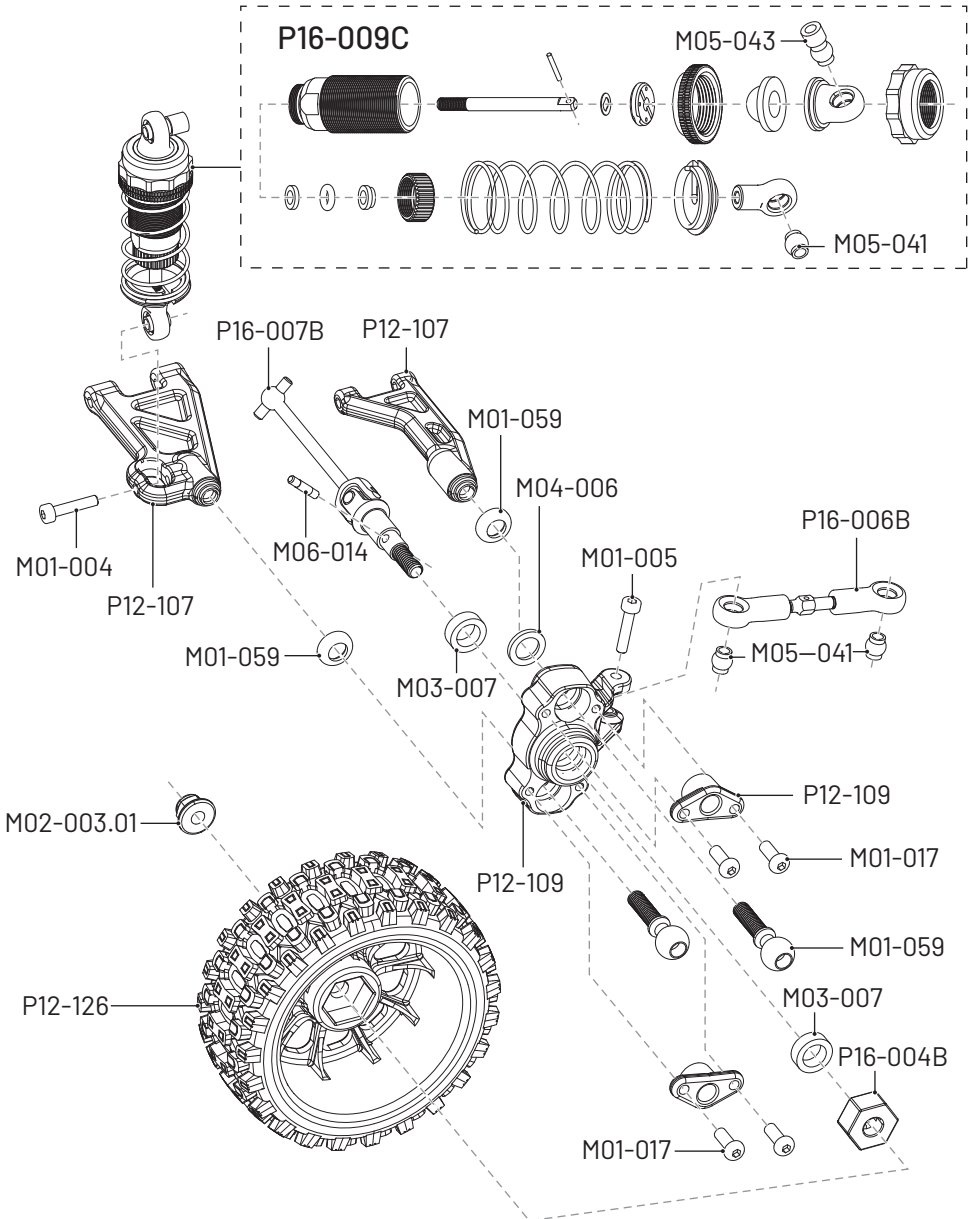

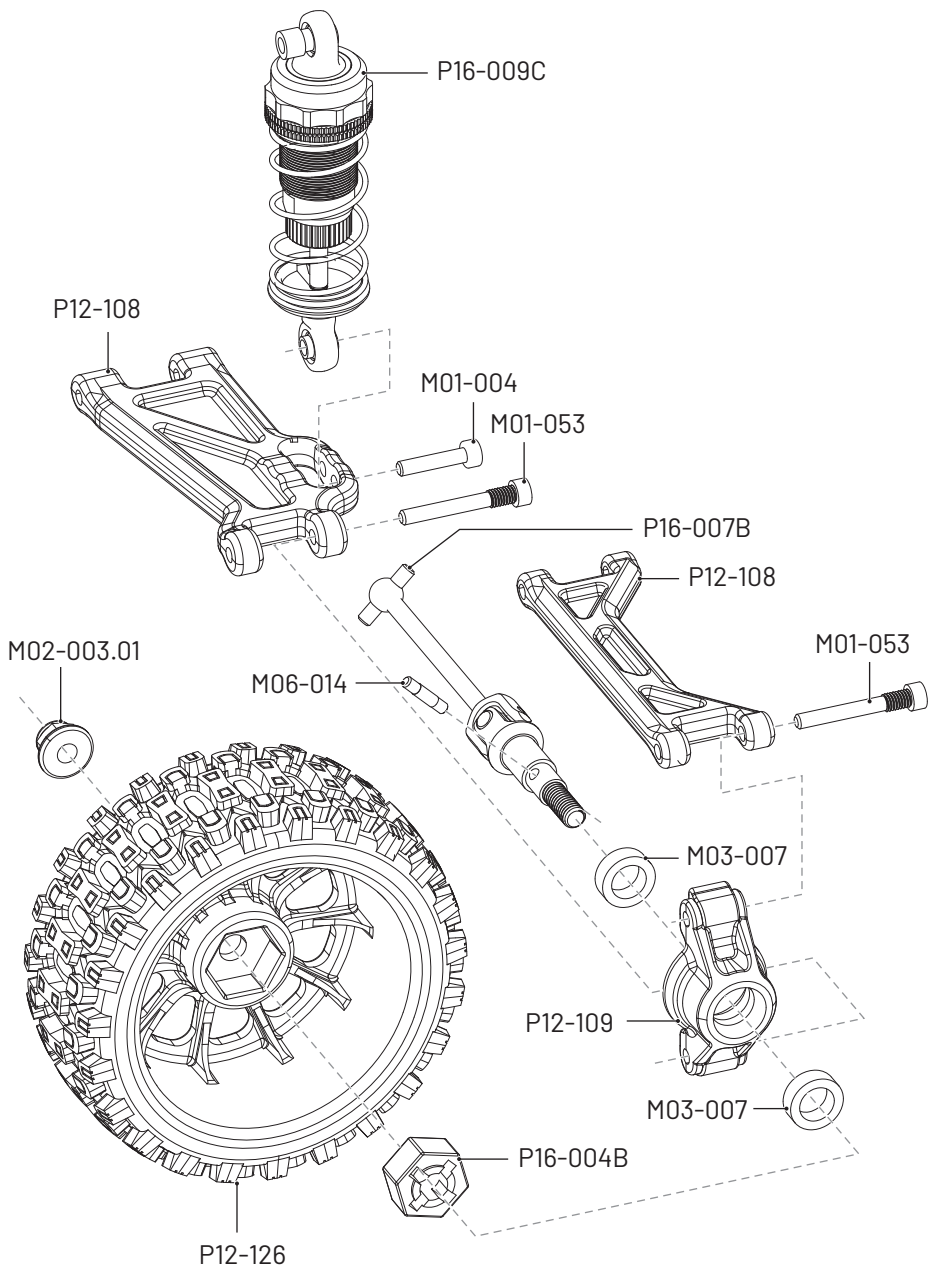

07-03 CENTER DIFFERENTIAL / ESC ASSEMBLY

P12-116C Center Differential (Steel)

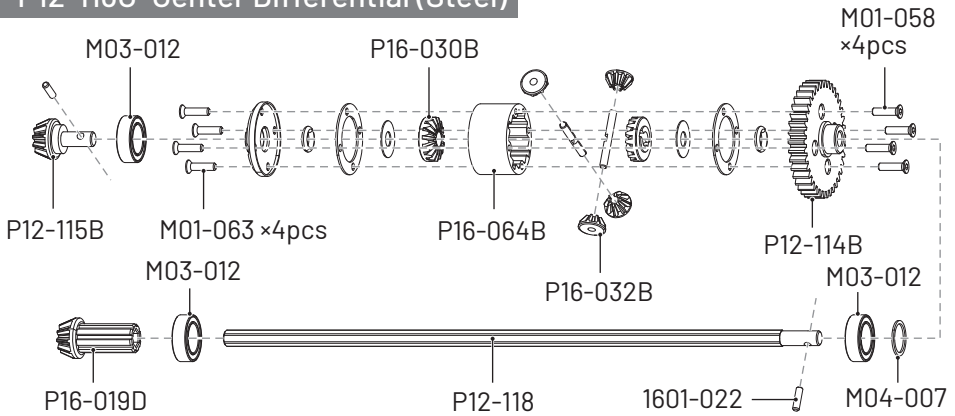

ESC

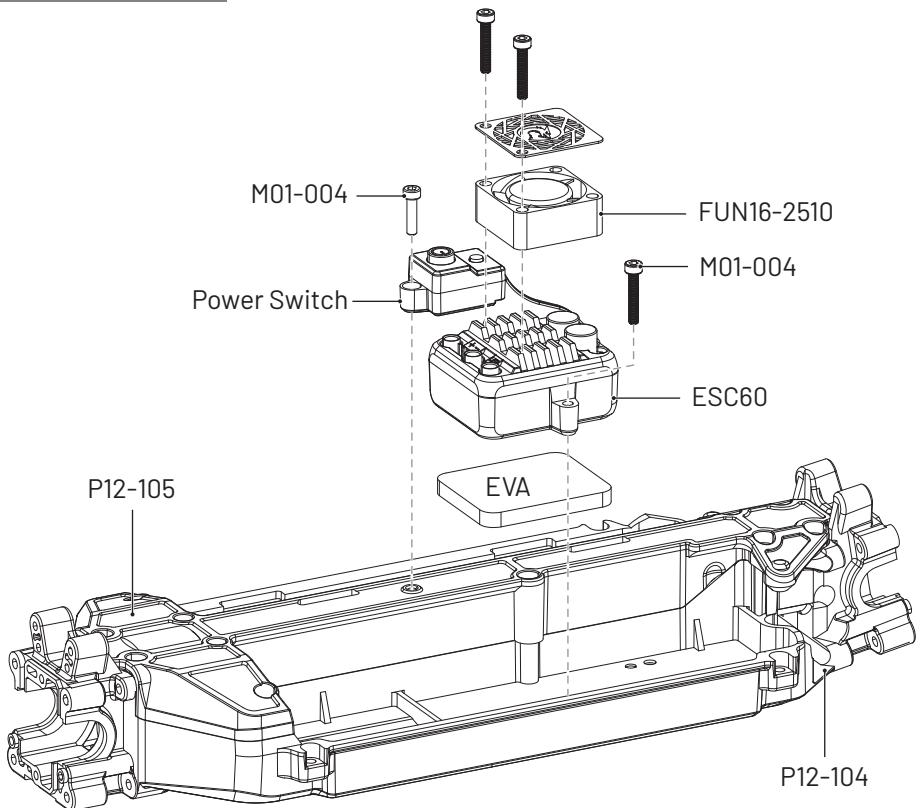

Motor

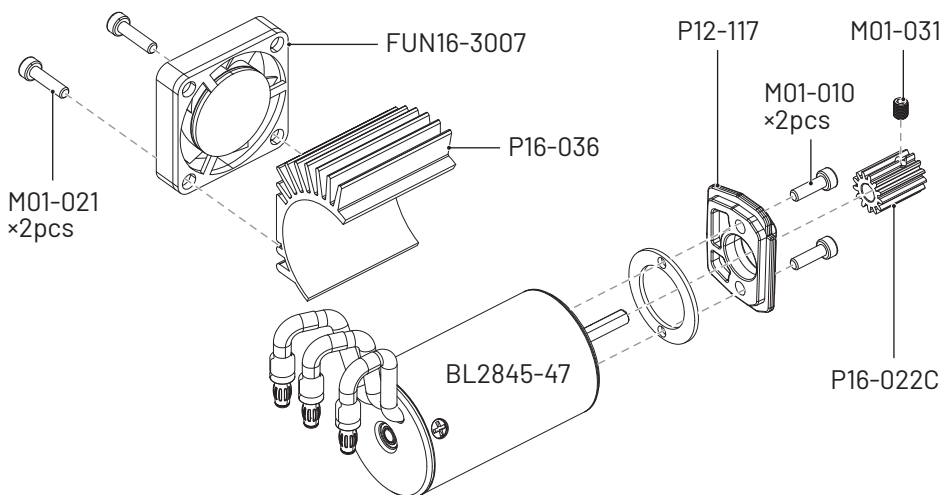

Receiver/Servo

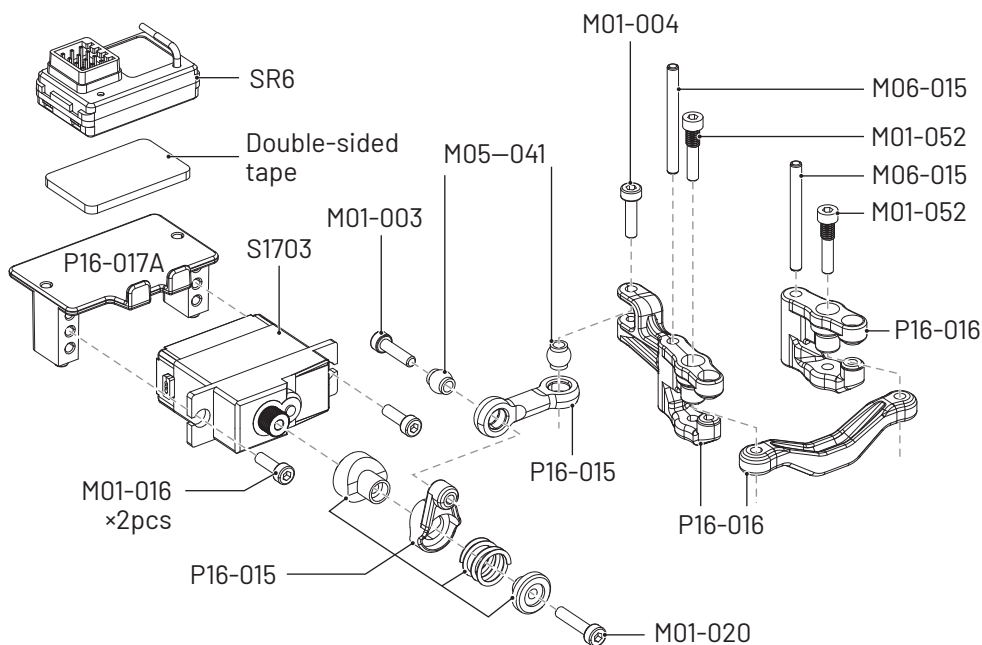

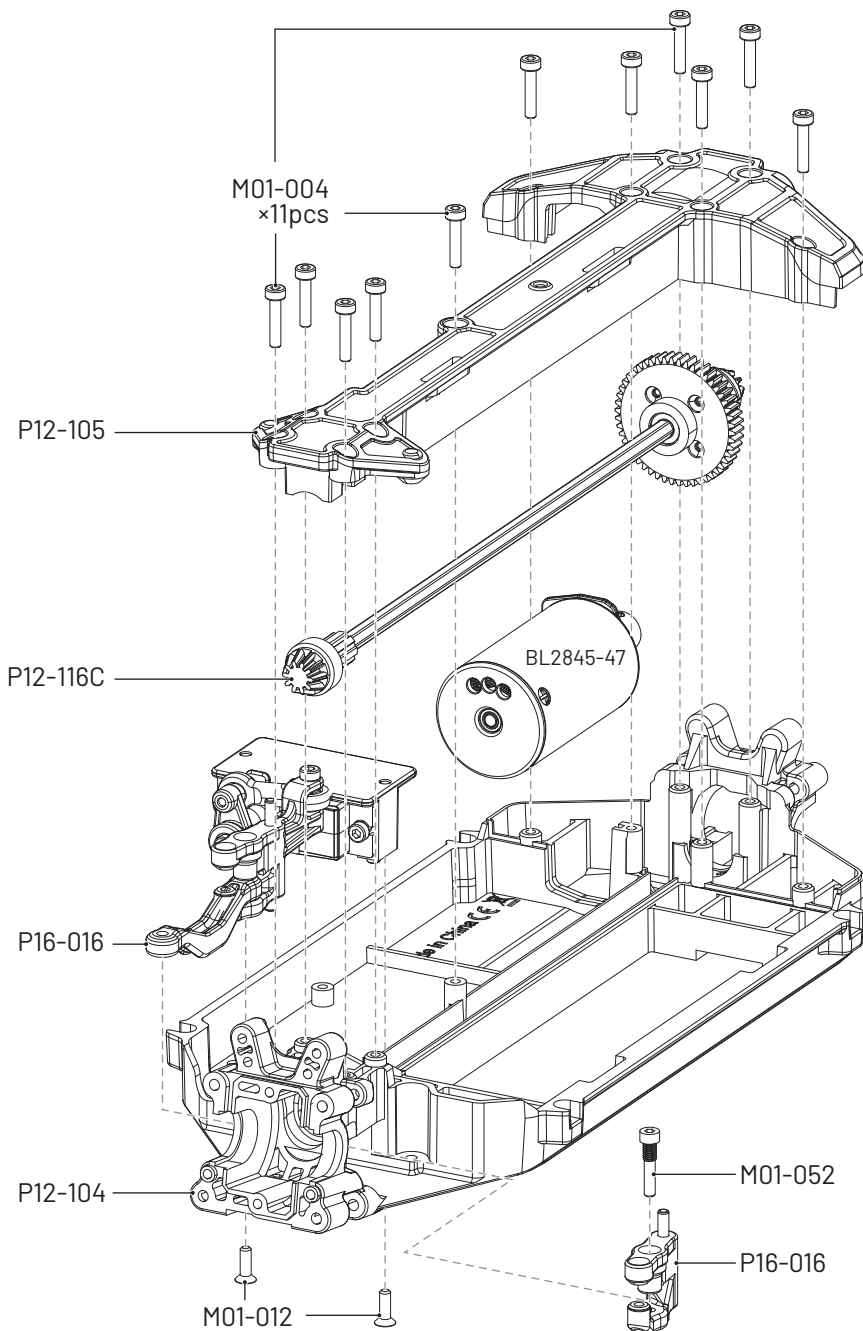

P16-023E Differential assembly (Steel)

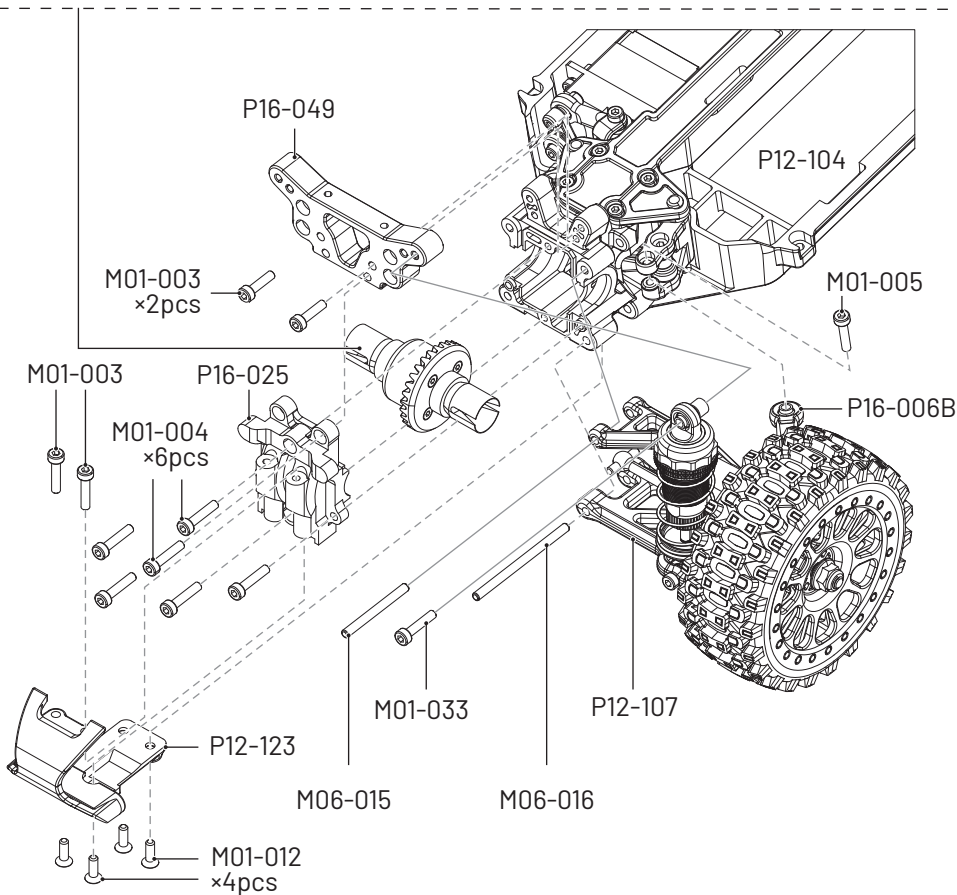
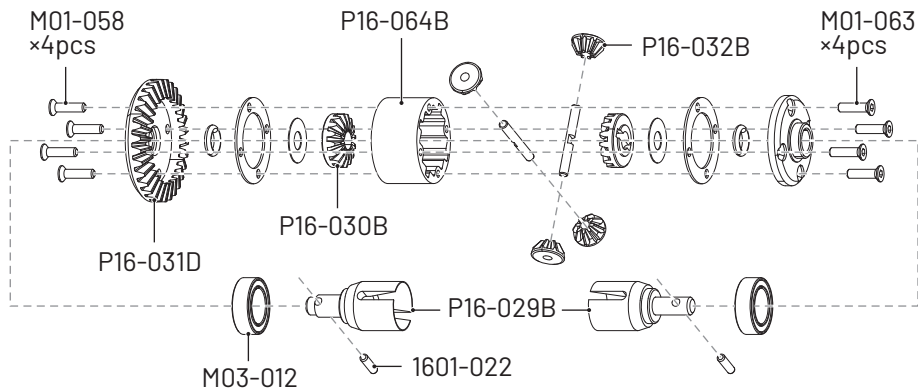

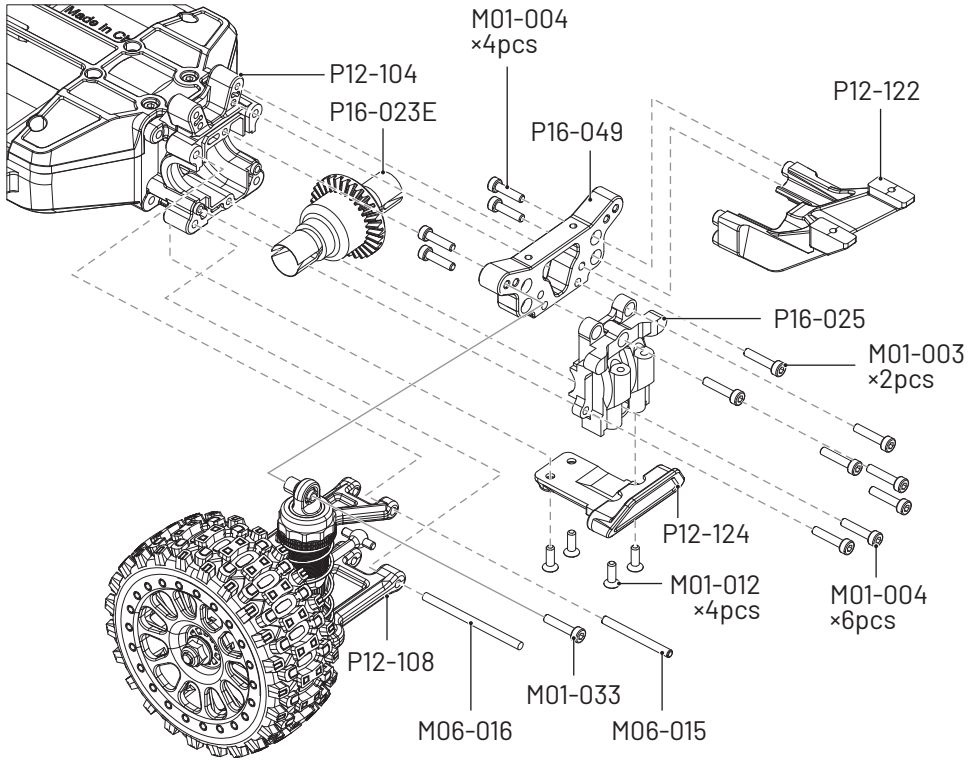
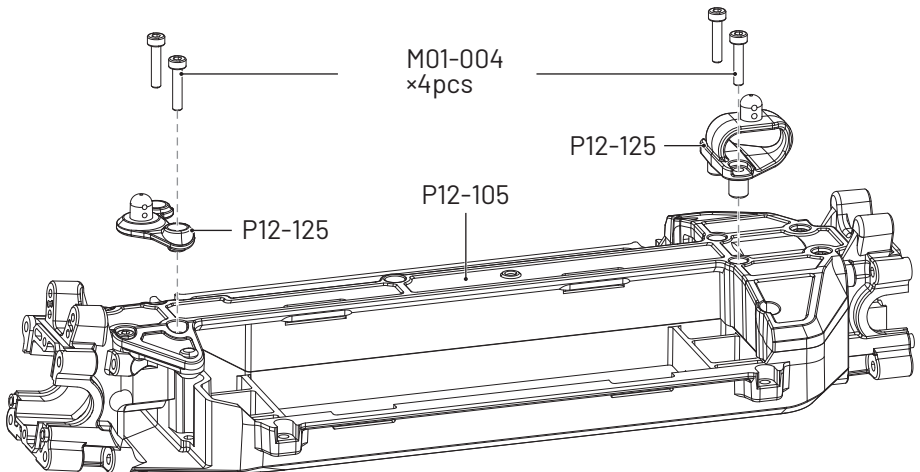
07-07**REAR BUMPER ASSEMBLY** (The left and right installation is the same)**07-08****BODY PILLAR**



Copyright © UDIRC®, All rights reserved. Made in China
Manufacturer: SHANTOU CITY UDIRC TECHNOLOGY COMPANY LIMITED
Address: Guangfeng Industrial Zone, Guangyi street, Chenghai District,
Shantou City, Guangdong Province, China

