

UdriRC

LAND CRUISER

PRADO PRO

OPERATING INSTRUCTIONS

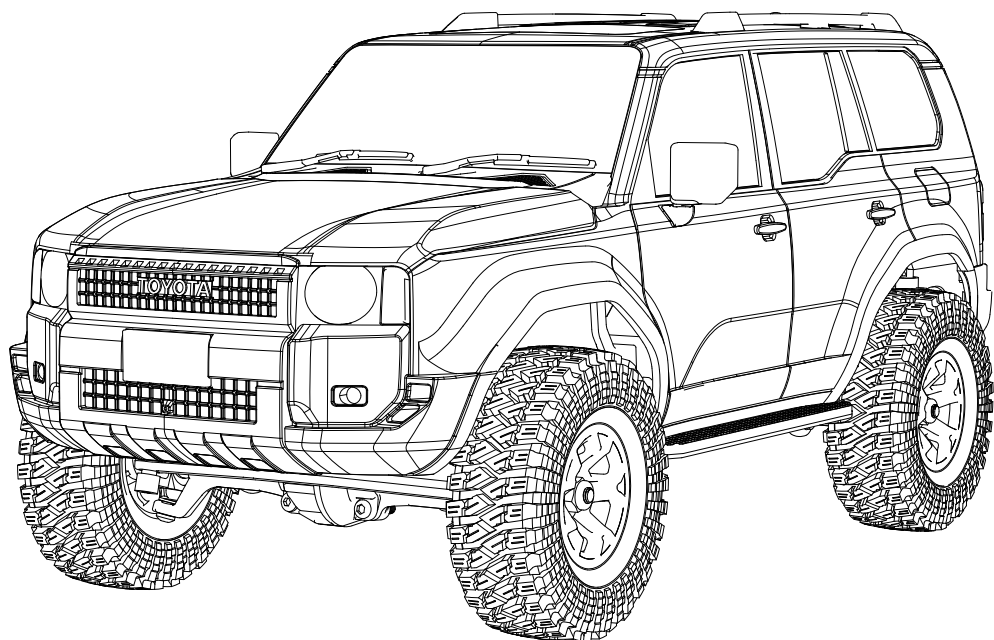

UCX18

4x4



14+
AGES

TABLE OF CONTENTS



01

WARNING & PRECAUTION & POLICY STATEMENT 04

	PAGE
01-Important Notice	04
02-Warning Statement	04
03-Use Sequential	05
04-Attention Statement	05
05-Battery Safety Statement	06
06-WEEE Compliance	06
07-FCC Note	07

03

QUICK START

	PAGE
Step 1 - Charge the Li-battery before playing	09
Step 2 - Open the truck body	10
Step 3 - Check the connecting on electronic parts	11
Step 4 - Install the model batteries	11
Step 5 - Assmble the truck body	11
Step 6 - Install the transmitter batteries	12
Step 7 - Power on transmitter & SCR for frequency pairing	12
Step 8 - Power OFF the SCR & transmitter	13
Step 9 - Product maintenance	13

04

SCR / LEDBOX / TRANSMITTER INSTRUCTIONS 14

01 SCR instructions	
SCR data	14
SCR operation tips	14
SCR installation	14

02 LEDBOX instructions	
LEDBOX data	15
LEDBOX installation	15

03 Transmitter instructions	
Transmitter data	16
Transmitter functions	16
F. ST.TRIM	17
ST.D/R	17
R. ST.TRIM	18
TH. TRIM	18
Transmitter indicator light	18
Mode	18
CH6, Drag brake	19
Power Switch	19
CH4, Throttle speed limiter switch	19
CH3, Control button	19
CH2, Throttle trigger	20
CH1, Steering wheel	20
Throttle/Steering Center Calibration	20

PAGE

08 VEHICLE SPECIFICATION

08 Vehicle data	
08 Electronic system spec.	
08 Transmission system spec.	
08 Structure system spec.	

02

PAGE

09

PAGE

21 BUYABLE ACCESSORIES LIST

21 Plastic parts & hardware	
22 Electronic devices	
22 Screw type	
22 Tool	

PAGE

23 TROUBLE SHOOTING

PAGE

24 EXPLOSION VIEW

05

06

07



01 - WARNING & PRECAUTION & POLICY STATEMENT

Remark: Including Section 01-01 to 01-07.

01-01

IMPORTANT NOTICE

- (1) The package or instruction manual contains important information and must be **RETAINED**.
- (2) Our company's products are improving all the time, design and specifications are subject to change without notice. All the information in this manual has been carefully checked to ensure accuracy, if any printing errors, our company reserves the final interpretation right.
- (3) The spare parts (including batteries and chargers) mentioned in the User Manual are subject to sales. KIT version not included electronic component. Configurations vary by version, please refer to the sales version.
- (4) Failure to follow these instructions (including PART 01, PART 03, and others) may result in injury to yourself or others. You may also cause property damage or model damage.
- (5) For more safety precautions, please refer to the "Disclaimer and Safety Operation Guidelines".
- (6) Usage: Please follow the instructions to install and operate the model.



Download the
operating guide

01-02

WARNING STATEMENT

Warning:

The product should only be used by adults and children over 14 years. Adult supervision is required for children under 14 years.

Hinweis:

Dieses Produkt ist für die Erwachsene und die Kinder ab 14 Jahren. Die Kinder unter 14 Jahren müssen von Erwachsenen beaufsichtigt werden.

Avertissement:

Ce produit est destiné aux adultes et aux enfants de plus de 14 ans. Les enfants de moins de 14 ans doivent être surveillés par des adultes.

Avvertimento:

Questo prodotto è destinato all'uso per i adulti e bambini di età superiore ai 14 anni. I bambini di età inferiore ai 14 anni devono essere sorvegliati da un adulto.

Advertencia:

Este producto es para adultos y niños mayores de 14 años. Los niños menores de 14 años deben ser supervisados por adultos.

警告: この製品は、大人と14歳以上の子供には使用対象です。

14歳未満の子供は大人の監視が必要です。

. ويحتاج الأطفال دون سن الرابعة عشره إلى رعاية البالغين

تحذير : هذا المنتج يستخدم فقط من قبل البالغين والأطفال فوق سن 14



DANGER!
Only suitable
for age 14+

Before Operation	<p>(1) Read the instruction manual in detail, or ask for the person with experience in operation, and read with the guardian if necessary.</p> <p>(2) Make sure all screws and nuts are properly tightened.</p> <p>(3) The transmitter and the vehicle should always use the battery with saturated power to avoid losing control of the model.</p> <p>(4) Please make sure that the throttle trigger is in the center position.</p>
During Operation	<p>(1) First turn on the power of the transmitter, and then turn on the power of the model.</p> <p>(2) Use this product only in open areas (>5x5m) without pedestrians.</p> <p>(3) DO NOT put fingers or any objects inside rotating and moving parts.</p>
After Operation	<p>(1) First turn off the model power, then turn off the transmitter's power, and take out the all battery.</p> <p>(2) Daily maintenance is required after the model is used.</p>

- (1) The model must stop immediately and check for the reasons when it is operating abnormal.
- (2) Keep in mind that people around you may also operate a radio control model.
- (3) The motor is a heating part, please do not touch it.
- (4) If you don't use the model for a long time, please raise the chassis to let the wheels hang in the air.
- (5) Please use this product only in empty place! It is strictly forbidden to use it on roads, living area, parks, indoor areas, children or places where people gather, otherwise injury may occur.



The product contains small and sharp parts. Keep away from children.



Be sure to read the instruction manual in detail, or ask for the person with experience in operation, and read with the guardian if necessary.

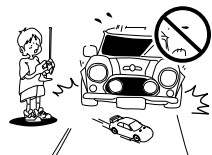

DO NOT operate in public streets or crowded places to avoid accidents.



Cutters, nippers and screw drivers need careful handling.

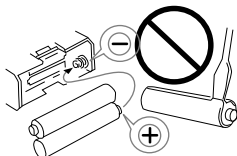

Please don't reverse contact or disassemble the battery, as this way will cause the battery to explode.

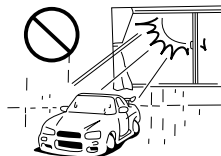

DO NOT put the model in high temperature, humidity and direct sunlight.

- Please read and observe all precautions before use. Improper use of battery may cause danger.
 - It is normal for the battery to heat up after operation. Please be careful when handling the battery. If the wire is worn, it is easy to short circuit and cause fire.
- 1) Pay attention to the polarity of the battery when installing or replacing the battery;
 - 2) Different types of batteries or old and new batteries should not be mixed;
 - 3) After use, please disconnect the power supply and pull out the plug;
 - 4) DO NOT charge the battery when it is bulging or expanding;
 - 5) Keep away from damp, corrosive environment and heat source;
 - 6) DO NOT short circuit, decompose or put the battery into fire;
 - 7) Please use the attached special charger to charge the battery;
 - 8) Please charge the battery under adult supervision;
 - 9) Remove the battery from the model before charging;
 - 10) DO NOT short circuit any terminals.



**▲ WARNING
FIRE HAZARD!**



Li-Po Battery Disposal & Recycling

Wasted Lithium-Polymer batteries must not be placed with household trash. Please contact local environmental or waste agency or the supplier of your model or your nearest Li-Po battery recycling center.



Please help the environment by disposing of your product responsibly at the end of its life. The wheeled bin symbol indicates that this product should not be disposed of in your household waste containers. Instead, the product should be disposed of by using a designated collection point for the recycling of waste electrical and electronic equipment. The Waste of Electrical and Electronic Equipment (WEEE) Directive (2002/96/EC) requires that the best available recycling techniques be employed to minimize the impact on the environment.

Recycling electronics helps by keeping harmful chemicals out of the environment, and also saves money by reusing precious metals. Remove any batteries and dispose of them and the product at your local authority's recycling facility. For more information about where you can drop off your waste equipment for recycling, please contact your local city office your household waste disposal service, or the location where you purchased this product.



This equipment has been tested and found to comply with the limits for a Class B digital device, pursuant to Part 15 of the FCC Rules. These limits are designed to provide reasonable protection against harmful interference in a residential installation. This equipment generates uses and can radiate radio frequency energy and, if not installed and used in accordance with the instructions, may cause harmful interference to radio communications. However, there is no guarantee that interference will not occur in a particular installation. If this equipment does cause harmful interference to radio or television reception, which can be determined by turning the equipment off and on, the user is encouraged to try to correct the interference by one or more of the following measures:

- Reorient or relocate the receiving antenna.
- Increase the separation between the equipment and receiver.
- Connect the equipment into an outlet on a circuit different from that to which the receiver is connected.

WARNING: Changes or modifications not expressly approved by the party responsible for compliance could void the user's authority to operate the equipment.

FCC Notice

The equipment may generate or use radio frequency energy. Changes or modifications to this equipment may cause harmful interference unless the modifications are expressly approved in the instruction manual. Modifications not authorized by the manufacturer may void user's authority to operate this device.

This device complies with Part 15 of the FCC Rules. Operation is subject to the following two conditions: (1) this device may not cause harmful interference, and (2) this device must accept any interference received, including interference that may cause undesired operation.

FCC Radiation Exposure Statement

The device has been evaluated to meet general RF exposure requirement.

The device can be used in portable exposure condition without restriction.



WARNING:

CHOKING HAZARD - Small parts. Not for children under 3 yrs.

Erstickende Gefahr - Kleine Teile. Nicht für Kinder unter 3 Jahren.

Danger d'étouffement - petites pièces. Pas pour les enfants de moins de 3 ans.

Peligro de asfixia - Pequeñas piezas. No para niños menores de 3 años.

مخاطر الخنق - اجزاء صغيرة. ليس للأطفال تحت 3 سنوات.





02 - VEHICLE SPECIFICATION

Remark: Including Section 02-01 to 02-04.

02-01 VEHICLE DATA

Model No.	UCX1802PRO
Vehicle Scale	1:18
Vehicle Size	L276×W123×H118mm
Vehicle Weight	522.8g (without battery)
Wheelbase	155.7mm
Wheel Track	101.6mm
Ground Clearance	21.7mm
Approach Angle	42.5°
Departure Angle	33.7°
Wheel Size	ø55.2×20.51mm

02-02 ELECTONIC SYSTEM SPEC.

Motor	Brushless Motor
ESC	2-in-1 speed control & receiver (SCR), refer to 04-01 for detail.
Battery	750mAh, 7.4V, XH2.54-3P, Lipo battery
Steering Servo	9g digital servo
Transmitter	Refer to 04-03 for detail.

02-03 TRANSMISSION SYSTEM SPEC.

Motor Gear	16T Powder Metal
Transmission Gear	Metal
Input Gear	Metal
Axle Shift Gears	Metal
Driveshaft	Metal

02-04 STRUCTURE SYSTEM SPEC.

Truck Body	ABS Injection molding
Axle	High-quality Nylon
Shock	Oil-filled Shock Absorber, ABS
Wheel Hex	High-quality Nylon
Girder	Metal
Motor Mount	High-quality Nylon



03 - QUICK START

Remark: Including Section 03-01 to 03-09.

03-01 STEP 1 - CHARGE THE LI-BATTERY BEFORE PLAYING

- The battery contains less power when leaving the factory, so it must be fully charged before use.
- When charging the battery, it must be disconnected from the SCR and separated from the model.
- The battery must be allowed to cool for 20 minutes after use before recharging.

- (1) Connect the included USB charging cable to the model-battery charging port;
- (2) Connect the USB cable with battery to USB port of your computer or USB adaptor (output 5V 2A)(not included);
- (3) Plug the adaptor to the household power supply;
- (4) When charging, the green LED will flash, and will become stable after fully charged. (Not support fast charging protocol!)

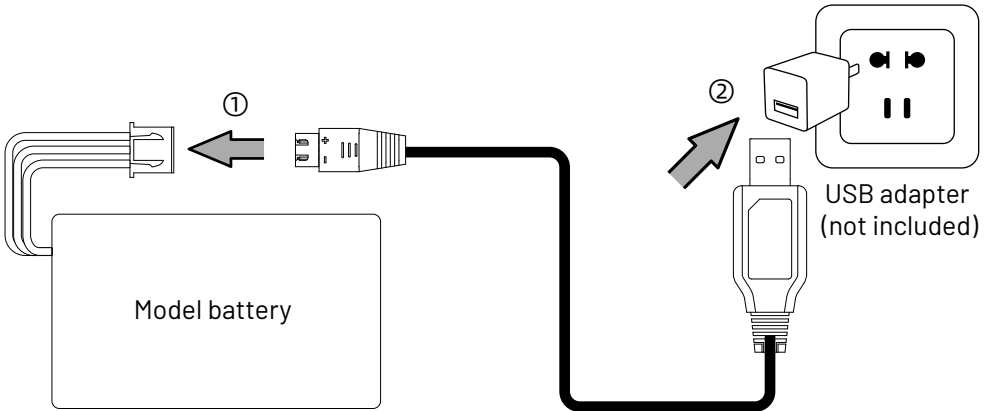

WARNING: MUST BE SUPERVISED WHILE CHARGING.

Please use the included USB charging cable and make sure it is properly connected.

Notes: Use a charger with appropriate current to avoid overcharging or over-discharging, which helps extend battery lifespan.

03-02 STEP 2 - OPEN THE TRUCK BODY

Step 2-1 Press ① (Buckle) inward to separate ② (Clip) and ③ (Body slot).

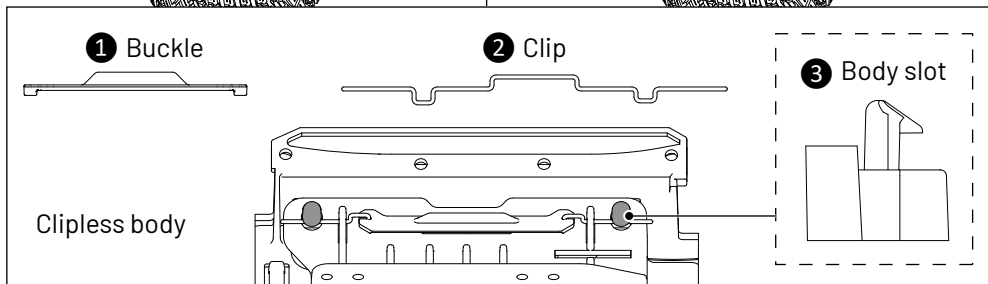
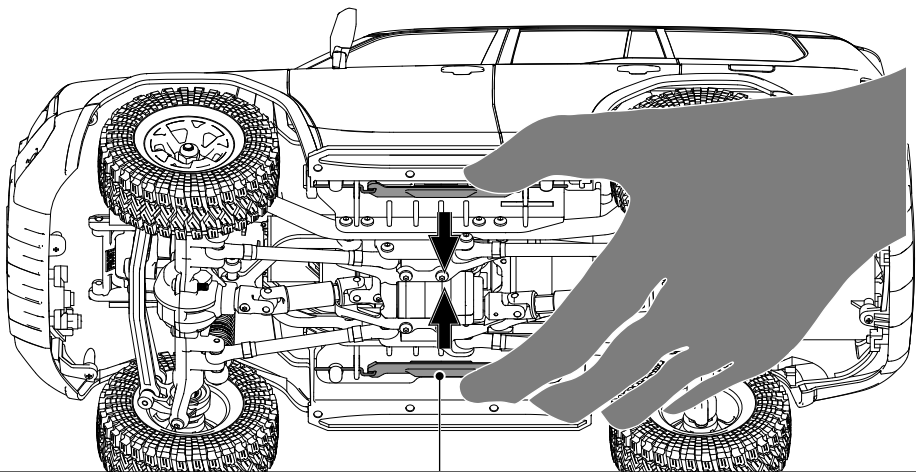

Step 2-2 Remove the body shell from ④ (Clipless body socket).

Note: The body shell and chassis are interconnected by a lighting harness.

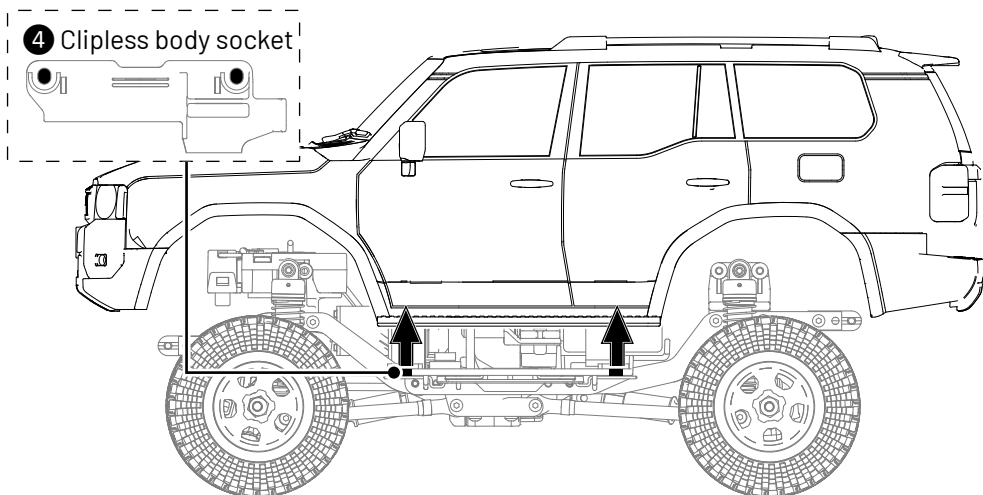

03-03 STEP 3 - CHECK THE CONNECTING ON ELECTRONIC PARTS

● After removing the truck body, check the connecting among SCR and other electric parts per the instruction of "Section 04-01-03".

03-04 STEP 4 - INSTALL THE MODEL BATTERIES

● Put the battery into the battery compartment, fix the battery with Velcro and then connect with the SCR. Take out the battery when not in use, otherwise the battery is easily damaged.

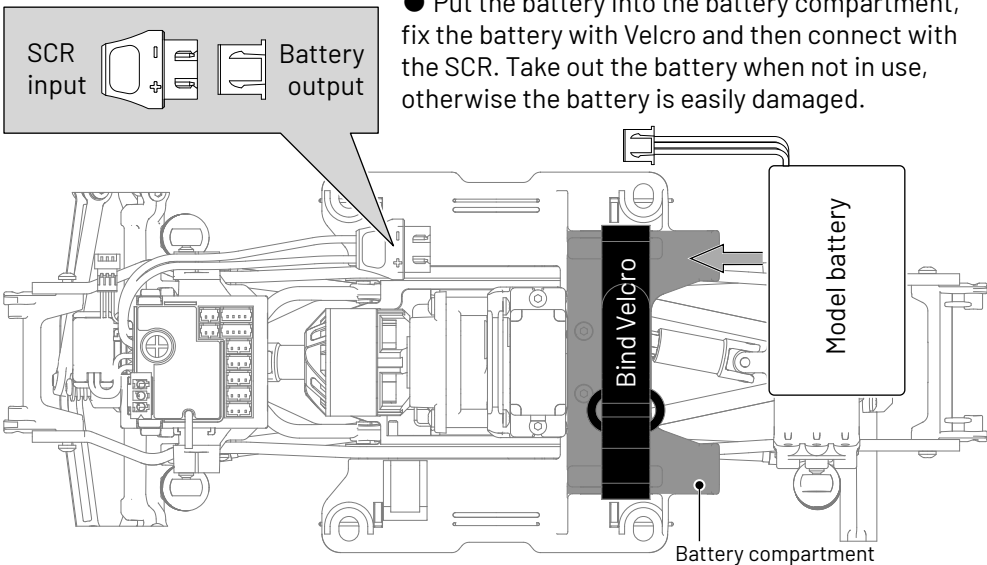

03-05 STEP 5 - ASSMBLE THE TRUCK BODY

Step 5-1: Insert ③ (Body slot) into

④ (Clipless body socket);

Step 5-2: Place ② (Clip) into the slot of ③ (Body slot).

The installation steps are the opposite of the removal process. Refer to Section 03-02 for details.

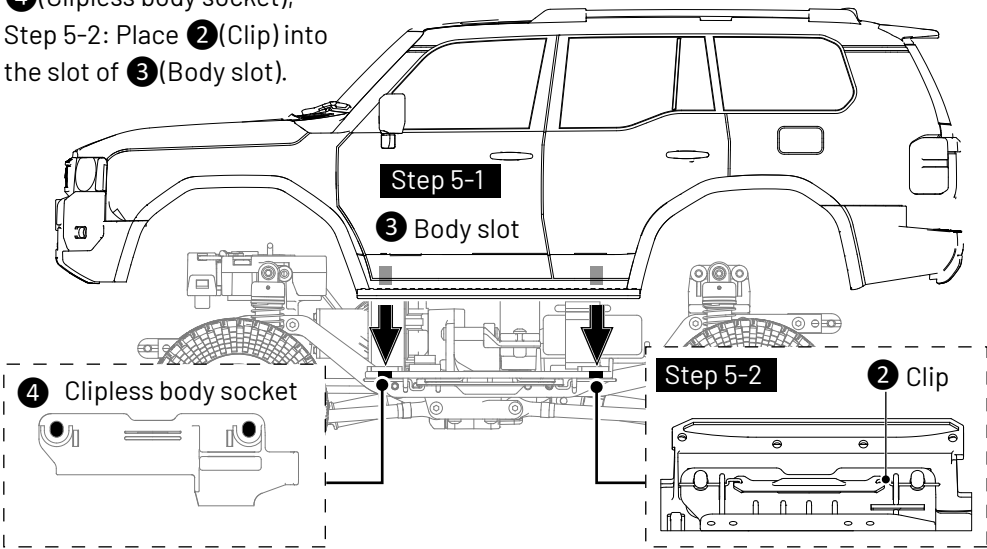

Open battery cover at the bottom of transmitter. Install batteries. Follow the direction of batteries designated in the inside of the battery box.

OPEN THE BATTERY COVER

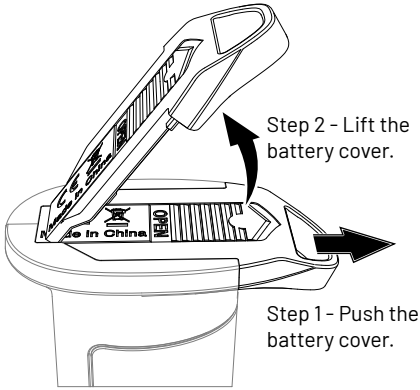

Input Power Method 2

- Step 1: Remove the 1.5V AA battery case.
 Step 2: Put the 7.4V Li-battery with connector type XH2.54-3pin inside the battery compartment.
 Battery compartment capacity: 70×37×19mm

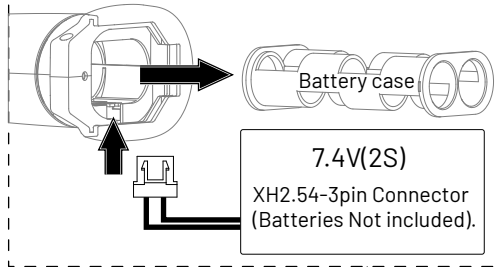

NOTE POLARITY DIRECTION

Input Power Method 1

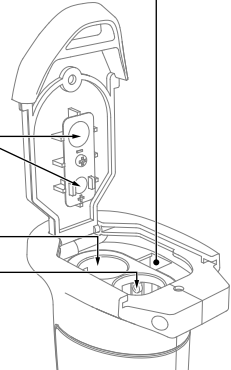
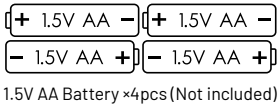

- (1) Always power ON your transmitter first, and then power on the SCR.
- (2) The device automatically frequency pairing successful. If all the lights keep bright, it indicates that the frequency pairing is successful. Otherwise, frequency pairing fails and needs to be done again. Refer to "Function 1" of "Section 04-03-12 CH3, CONTROL BUTTON".

Always power ON your transmitter first

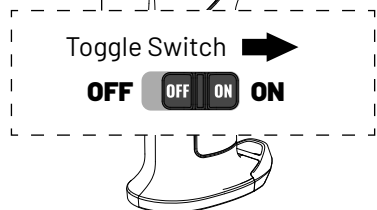

And then power on the SCR

Bottom view of the tail
Toggle switch

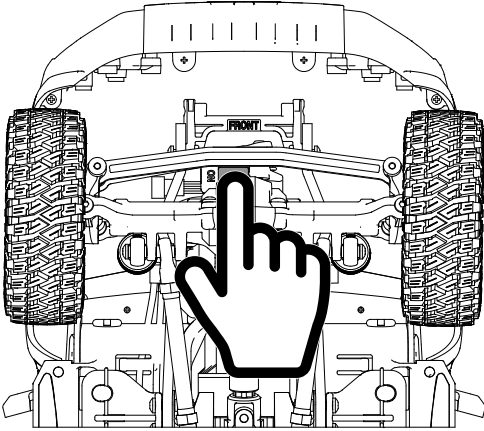

You can play now!

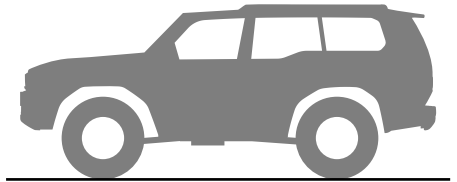

Placed on Horizontal ground

03-08 STEP 8 - POWER OFF THE SCR & TRANSMITTER

- (1) First, turn off the vehicle's SCR power and remove the battery. Open the truck body and refer to 03-02 for details.
- (2) Second, turn off the transmitter power and remove the battery. Open the battery cover and refer to 03-06 for details.
- (3) **IMPORTANT:** Always power OFF the SCR before the transmitter.

03-09 STEP 9 - PRODUCT MAINTENANCE

When not in use,
remove the battery
from the model and
transmitter.

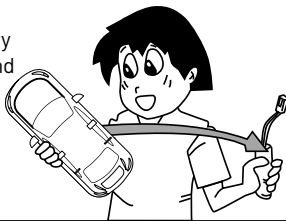

Please remove the sediment and
dirt on the car completely and
must be kept dry after play.



Apply lubricating oil to
external metal parts.



Please separate the car and
battery when not in use.





04 - SCR / LEDBOX / TRANSMITTER INSTRUCTIONS

Remark: Including Section 04-01 to 04-03.

04-01 SCR INSTRUCTIONS

04-01-01 SCR DATA

Model	SCR2T
RF Standard	2.4GHz
Input Power	2S(7.4V)
Rated current	10A
Size	33.4×30×12.3mm
Power Connector	XH2.54-3P
Motor Limit	2S
Motor Connector	PH2.0-3P

04-01-02

OPERATION TIPS



(1) When starting to play the vehicle, always power ON your transmitter before the SCR.

(2) After playing the vehicle, always power OFF the SCR before the transmitter.

04-01-03

SCR INSTALLATION

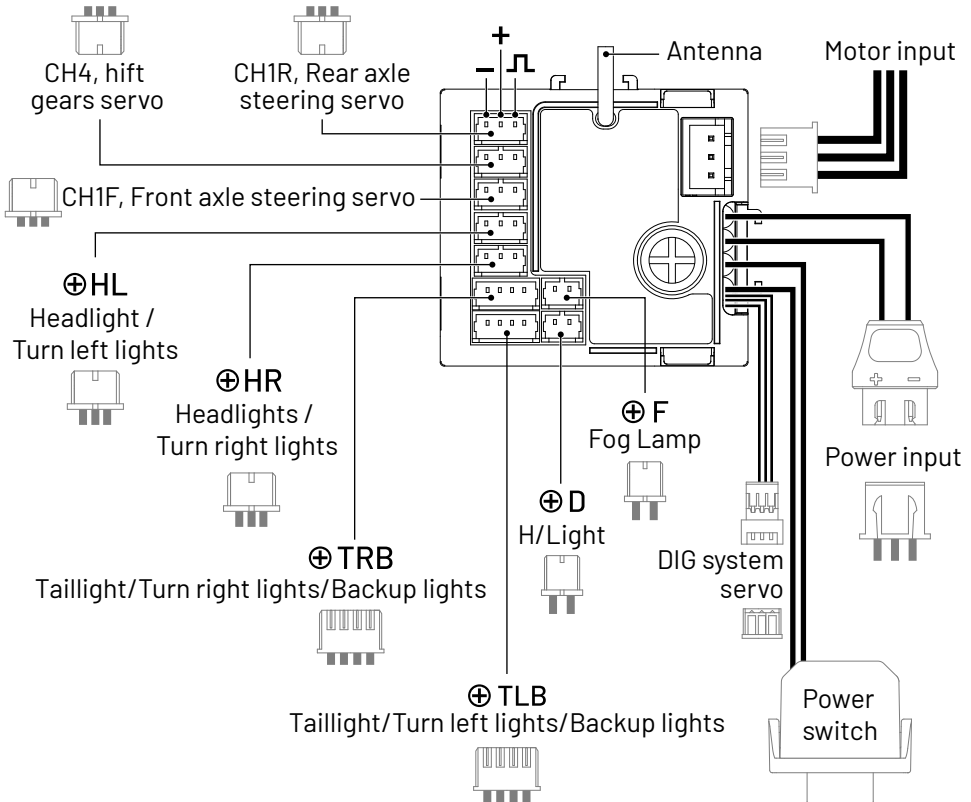

04-02 LEDBOX INSTRUCTIONS

04-02-01

LEDBOX DATA

Model

LEDBOX01

Input Power

5V

04-02-02

LEDBOX INSTALLATION

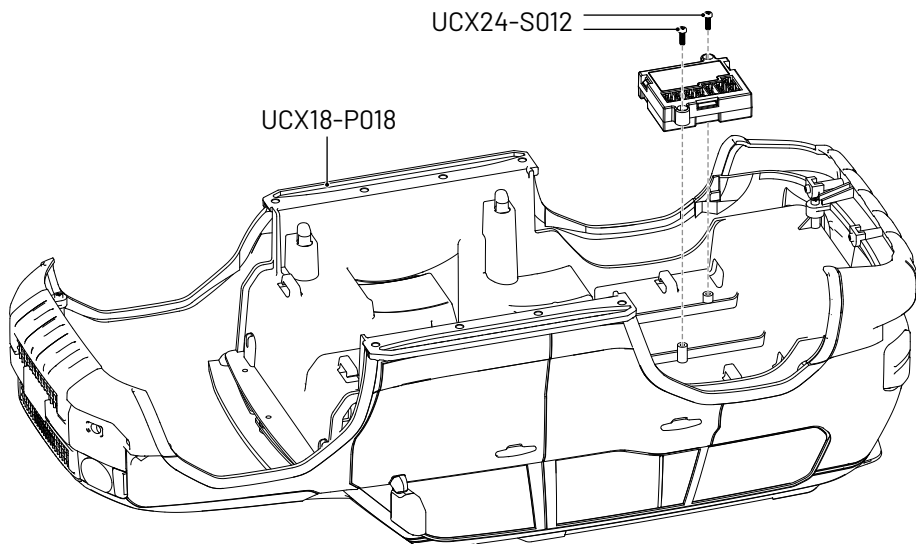
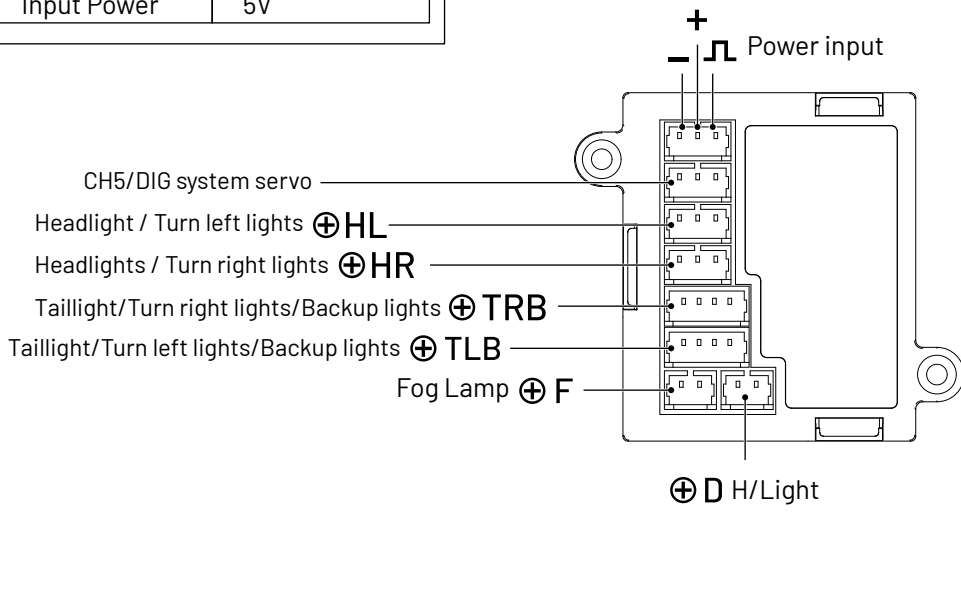

04-03 TRANSMITTER INSTRUCTIONS

Before installing and operating your transmitter, please take a few minutes to familiarize yourself with the various features of the system by reading this instruction manual thoroughly.

04-03-01

TRANSMITTER DATA

Model	UA42-A
Control Type	Proportional
Frequency Band	2.4GHz
Channels	6
Control Distance	197 ft (60m)
Iput Power Method 1	1.5V AA Battery × 4pcs
Iput Power Method 2	7.4V Battery with connector type XH2.54-3pin

04-03-02

TRANSMITTER FUNCTIONS

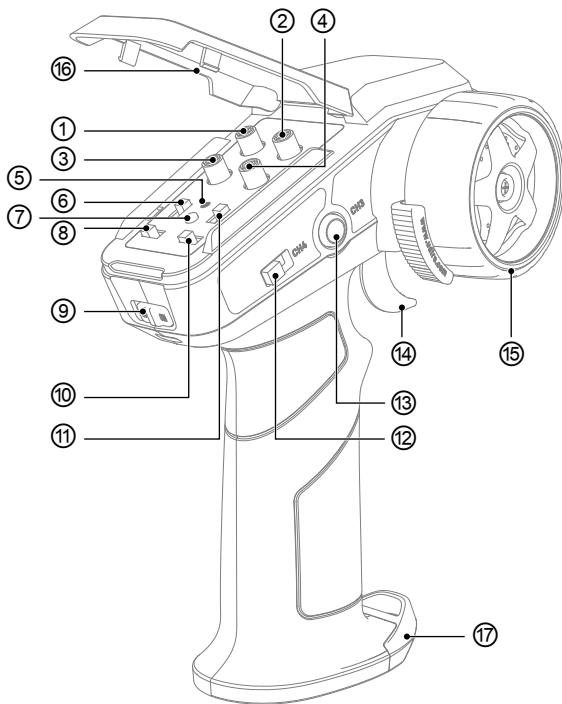

① F.ST.TRIM Front Steering Trim
Refer to 04-03-03 for detail.

② ST.D/R Steering Dual Rate
Refer to 04-03-04 for detail.

③ R.ST.TRIM Rear Steering Trim
Refer to 04-03-05 for detail.

④ TH.TRIM Throttle Sub-trim
Refer to 04-03-06 for detail.

⑤ Transmitter Indicator
Refer to 04-03-08 for detail.

⑥ CH5 Expansion Channel.

⑦ Mode selection button
Refer to 04-03-08 for detail.

⑧ TH.REV Reverse for CH2

⑨ Power Switch
Refer to 04-03-10 for detail.

⑩ ST.REV Reverse for CH1

⑪ CH6, Drag Brake
Refer to 04-03-09 for detail.

⑫ CH4
Throttle Speed Limitation Switch,
refer to 04-03-11 for detail.

⑬ CH3
Frequency Paring / Lamp control,
refer to 04-03-12 for detail.

⑭ CH2, Throttle Trigger
Control the vehicle to forward, backward,
refer to 04-03-13 for detail.

⑮ CH1, Steering Wheel
Control the vehicle to turn right / left,
refer to 04-03-14 for detail.



⑯ Regulatory Interface Cover
To avoid dust or water splash.

⑰ Battery Cover
Battery installation, refer to 03-06 for detail.

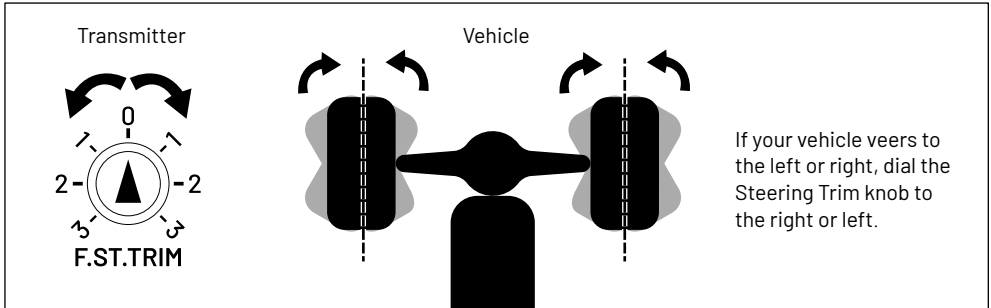
Front Steering Trim: Trim adjustment allows you to finely tune the inputs from your transmitter. It's the dial you reach for when your RC car isn't tracking straight. The steering trim is what helps navigate the RC car in a straight line.

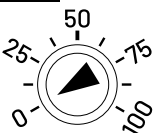
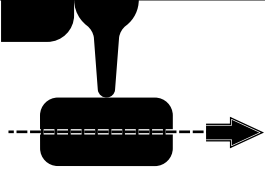

Steering Dual Rate: Steering Dual Rate knob can be set to control the steering throw:
 (1) Turning the knob clockwise to increase the steering throw.
 (2) Turning the knob anticlockwise to reduce the steering throw.

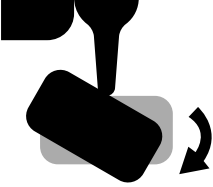
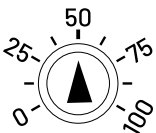
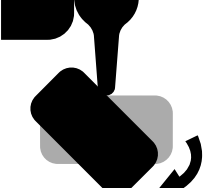
<p>Sample 1</p>  <p>ST.D/R</p>	<p>Step 1- Set the ST.D/R knob to "0" position.</p> <p>Step 2- Dia the steering wheel of transmitter to the end.</p>		<p>Result: The wheels cannot turn right or left, only can run straight, even you dia the steering wheel to the end.</p>
<p>Sample 2</p>  <p>ST.D/R</p>	<p>Step 1- Set the ST.D/R knob to "25" position.</p> <p>Step 2- Dia the steering wheel of transmitter to the end.</p>		<p>Result: The wheels can turn right or left under 25% steering throw, turn wider than 0%(Sample 1).</p>
<p>Sample 3</p>  <p>ST.D/R</p>	<p>Step 1- Set the ST.D/R knob to "50" position.</p> <p>Step 2- Dia the steering wheel of transmitter to the end.</p>		<p>Result: The wheels can turn right or left under 50% steering throw, turn wider than 25%(Sample 2) and 0%(Sample 1).</p>

Note: Above are the samples to help the players to under the ST. D/R function.

The rear wheels need to be upgraded to be steerable before they can be used.

Rear Steering Trim: Trim adjustment allows you to finely tune the inputs from your transmitter. It's the dial you reach for when your RC car isn't tracking straight. The steering trim is what helps navigate the RC car in a straight line.

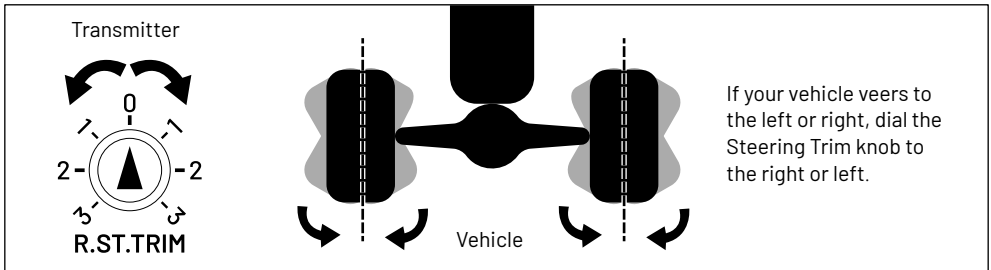

Before starting up, it must be set to "0".

Throttle trim allows you to trim the values on the transmitter. It enables the car to cruise automatically at extremely low or extremely fast speeds: (1) Turn the knob clockwise and the car will move forward for cruising. (2) Turn the knob counterclockwise and the car will move backward for cruising.

Turn the knob counterclockwise. The car will cruise back. The larger the number, the faster the speed.

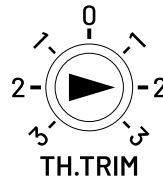
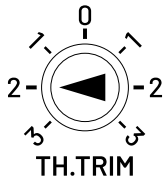

Turn the knob clockwise and the car will cruise forward. The larger the number, the faster the speed.

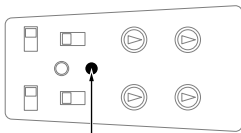

Indicator light

Situation 1: When the signal is weak or interrupted, the indicator will flash quickly.

Situation 2: When the power of the transmitter is low, the indicator light will flash slowly.

The above situation should be handled as soon as possible to avoid accidents.

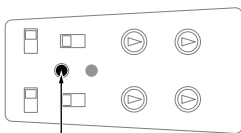

MODE

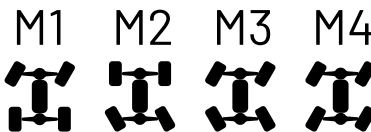

Default front wheel steering (M1), other modes available with purchase of rear wheel upgrade kit.



Activated, releasing the throttle triggers automatic braking.



Vehicles with dragging brakes coast a shorter distance.



Vehicles without dragging brakes coast farther.

OFF  ON

Please make sure the transmitter throttle trigger and Steering wheel are normal before starting up. Do not touch the throttle trigger when turning on the power of the transmitter.

After powering on, the transmitter will automatically pair with the device, and the indicator light will remain steadily lit. If the indicator light blinks, please refer to section (04-03-12, Function 1) for troubleshooting instructions.

The throttle speed limit function includes three speed : low speed, neutral speed and high speed.

Low speed are suitable for crossing roadblocks or climbing slopes. When in neutral speed, the motor is idling. The high speed is suitable for flat ground.

L



Low speed

N



Neutral

H



High speed

Function 1: Frequency Paring

If auto-pairing fails, turn off all power sources.

① Restart the SCR power supply; ② Press the CH3 button to turn on the transmitter power, then release CH3. When all the lights keep bright, it indicates that the frequency pairing is successful.

Function 2: Short press to headlights switch. Long press for 3 seconds switches the fog lights.

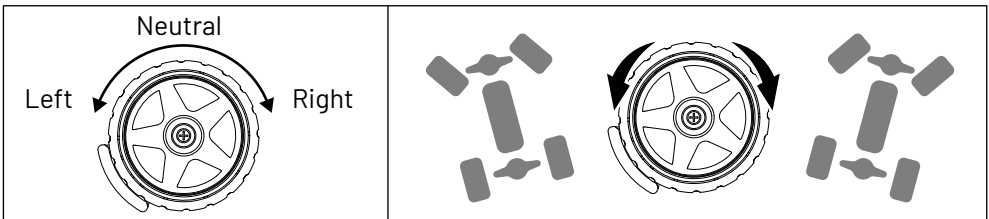
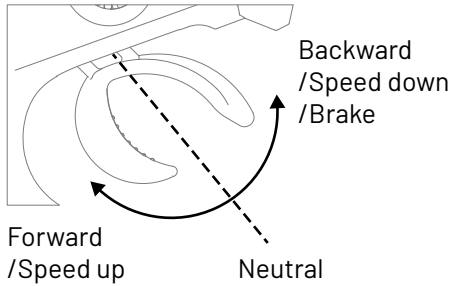

It need to upgrade the lighting components to use.

Turn on the emergency flashers by twisting it left to hold for a maximum of 3 seconds.



Turn on the high lights by twisting it right to hold for a maximum of 3 seconds.

- 1) Turn off both the vehicle and the transmitter.
- 2) Push the throttle trigger and steering wheel to their full range.
- 3) Turn on the transmitter power, then release the throttle trigger and steering wheel.
- 4) Turn the steering wheel to the left/right full range multiple times.
- 5) Pull the throttle trigger forward/backward to the full range multiple times.
- 6) Press the CH3 button once to save. Calibration is now complete.
- 7) Turn off the transmitter power.

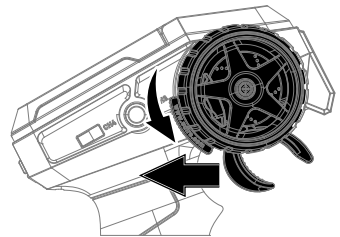



05 - BUYABLE ACCESSORIES LIST

Remark: Including Section 05-01 to 05-04.

05-01 PLASTIC PARTS & HARDWARE

Part#	Name
UCX18-P018A/B	Body assembly
UCX18-P019	Body accessories
UCX18-P020	Lampshade
UCX18-P021	Front and rear bumper
UCX18-P022	Center driveshaft
UCX18-P023	Center differential housing
UCX18-P024	Support plate
UCX18-P025	Shock absorber(Plastics)
UCX24-P064	Steering hub set
UCX18-P027	Front axle(Plastics)
UCX18-P028	Rear axle(Plastics)
UCX18-P029	Front/Rear axle rod
UCX18-P030	Y shape linkage
UCX18-P031	Steering linkage
UCX18-P032	Servo linkage
UCX18-P033	Servo mounts
UCX18-P034	Girder support
UCX18-P035	Clipless body
UCX18-P036	Front axle assembly
UCX18-P037	Rear axle assembly
UCX18-P038	Central transmission assembly
UCX18-M004	Girder
UCX18-M005	Gearbox teeth
UCX18-M006	Limit washers
UCX18-M007	Gear spindle
UCX18-M008	Gearbox transmission shaft
UCX24-P037	Motor gear
UCX24-P061	Wheel
UCX24-P063	Wheel adapters
UCX24-P081	Axle shift teeth
UCX24-P083	Gear pulling shaft
UCX24-M007	Transmission gear shaft
UCX24-M014	Front axle CVD driveshaft
UCX24-M015	Rear axle driveshaft
UCX24-M016	Gearbox axis (short)

05-02 ELECTRONIC DEVICES

Part#	Name
UCX24-P071	Steering sevro
UCX24-P072	Variable speed servo
BL1808-15	Brushless motor
MB75074	Model battery
UCX24-E005	USB Charger
UCX18-L002	Lamp group
UA42-A	Transmitter
SCR2T	2in1 Speed control & Receiver
LEDBOX01	Lighting Control Box

05-03 SCREW TYPE

Part#	Name
UCX24-S014	Hollow ball (Ø4×4.7mm)
UCX18-M014	Hollow ball (Ø4×9.5mm)
UCX24-M018	Steering washers
UCX24-M019	Pin (Ø1.5×6mm)
UCX24-M011	Ball bearing (Ø3×Ø6×2.5mm)
UCX24-M020	Ball bearing (Ø4×Ø7×2mm)
UCX24-M021	Ball bearing (Ø6×Ø10×3mm)
UCX24-M022	Ball bearing (Ø7×Ø11×3mm)
UCX24-M012	Ball bearing (Ø4×Ø7×2.5mm)
UCX24-S006	Hollow ball screw (Ø4×9.3mm)
UCX18-S001	Hexagon socket button head machine screw (Ø2.0×10mm PM)
UCX24-S001	Hexagon socket button head machine screw (Ø1.4×5mm PM)
UCX24-S005	Hexagon socket button head machine screw (Ø2.0×6mm PM)
UCX24-S010	Hexagon socket button head machine screw (Ø2.0×12mm PM)
UCX24-S011	Hexagon socket button head machine screw (Ø2.0×15mm PM)
UCX24-S012	Hexagon socket button head machine screw (Ø1.6×6mm PM)
UCX24-S013	M2.5 Hex flanged nylon lock nut
UCX24-S015	Hexagon socket head cap machine screw (Ø1.4×6mm HM)

05-04 TOOL

Part#	Name
HS-RTW01	screwdriver set (H1.27/1.5/2.0/2.5/3.0, C-HS-M4)



06 - TROUBLESHOOTING

PROBLEM		POSSIBLE REASON	SOLUTION
Vehicle Not Running	Model battery low or damaged.		Install Fully Charged Battery.
	SCR wires or motor worn or broken.		Check Status, Reconnect and Insulate.
	SCR overheating triggers high-temperature protection.		Stop Driving, SCR or Motor Must Cool.
	Motor damaged.		Replace New Unit.
	SCR damaged.		Replace New Unit.
	Wheels or drive shaft entangled with debris.		Check Components, Clear Debris.
	Vehicle out of control range.		Operate Vehicle Within Transmitter Control Range.
Short Run Time, Poor Performance	Battery damaged or not fully charged.		Check Status, Replace or Charge.
	Motor dirty or damaged.		Clean, Check Condition or Replace.
	Terrain resistance causes excessive power consumption.		Play on Other Terrain.
	Drive system dirty or damaged.		Clean, Check Condition or Replace.
Limited Steering Angle	Steering travel rate on transmitter set incorrectly.		Adjust steering travel rate, refer to section 04-03-04.
	Steering components damaged.		Check components and replace.
	Transmitter steering wheel not centered.		Calibrate steering wheel, refer to section 04-03-15.
Transmitter Indicator Not Lit, or Unable to Control Vehicle	Transmitter battery low or installed incorrectly.		Replace new battery, refer to section 03-06.
	Transmitter and SCR paired incorrectly.		Re-pair, refer to section 04-03-12.
	Transmitter damaged.		Replace new unit.
Steering/Throttle Intermittent Operation	SCR overheating causes shutdown.		Stop driving, SCR or motor must cool.
	Transmitter and SCR paired incorrectly.		Check for interference sources, or re-pair.
Vehicle Moves Left/Right Unsteadily	Servo not set correctly.		Adjust servo setup.
	Steering components damaged.		Check and replace components.
	Drive system dirty or damaged.		Clean, check or replace.
Steering/Throttle Operation Reversed	"TH.REV" or "ST.REV" set opposite on transmitter.		Adjust "TH.REV" or "ST.REV".
	Check SCR-to-motor wire connections are correct.		Disconnect and reconnect.
Speed Lower Than Nominal	Lower speed selected on throttle limit switch.		Select higher speed on throttle limit switch.
	Pinion gear stuck on motor mount.		Remove motor mount to adjust pinion gear.
Long Frequency Matching Time	Signal interference.	Restart vehicle and transmitter.	
Operation Delay	Possible obstacles or interference.	Remove or avoid obstacles or interference.	
Vehicle Automatically Moves Forward (Backward) or Makes "en..." Sound		Transmitter issue.	Restart transmitter, or adjust throttle neutral position, refer to section 04-03-06 or 04-03-15.



07 - EXPLOSION VIEW

Remark: Including Section 07-01 to 07-07.

07-01 BODY & TRUCK BED ASSEMBLY

UCX18-P018

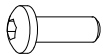
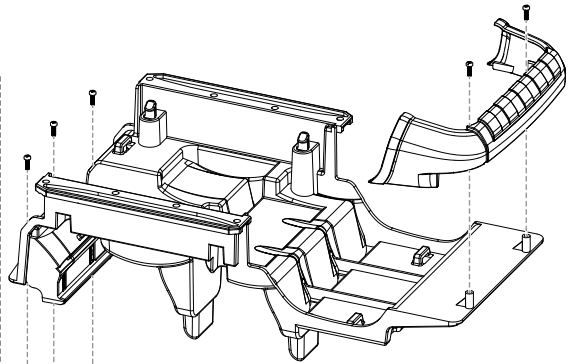
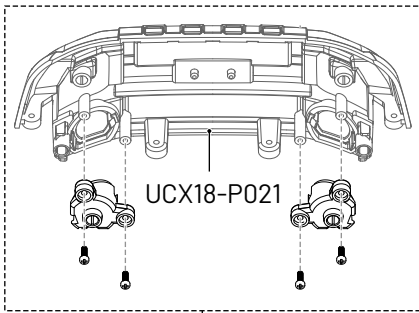

UCX24-S012
×23pcs

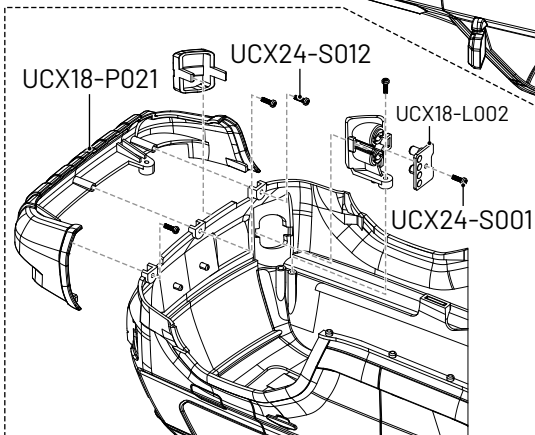
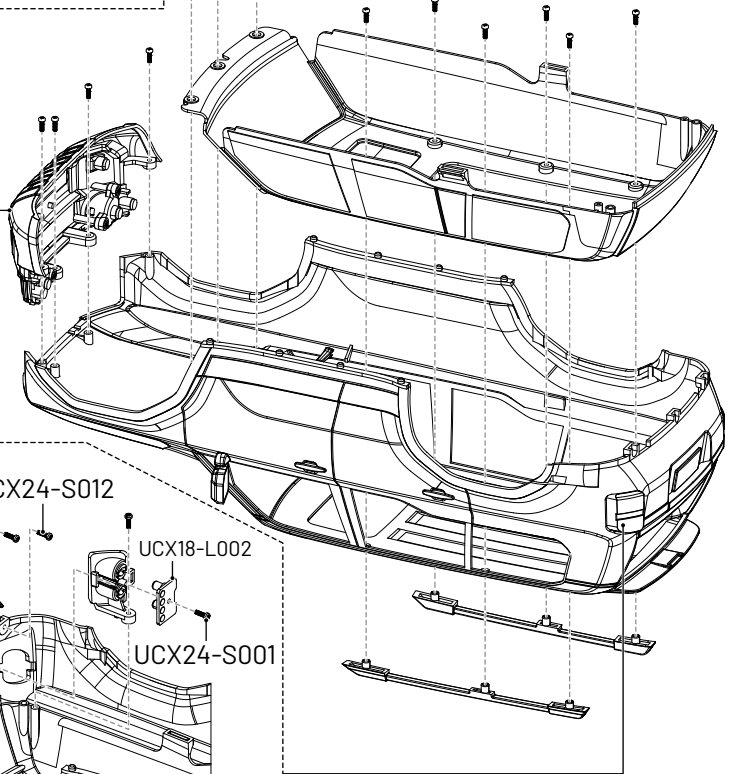

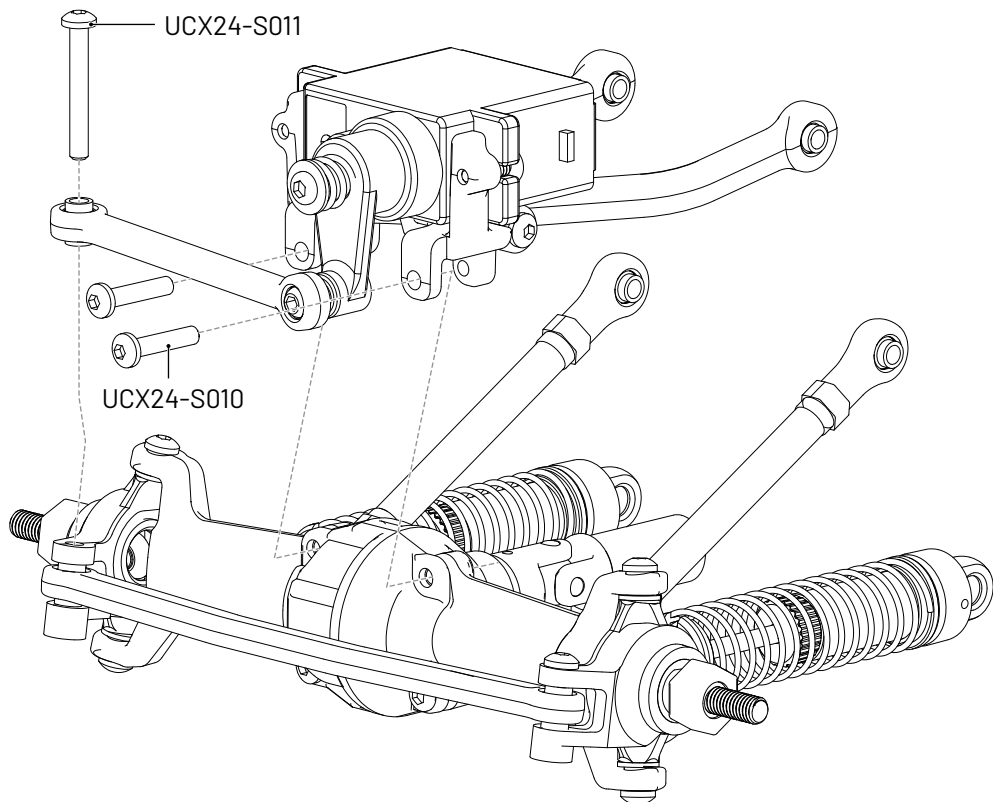
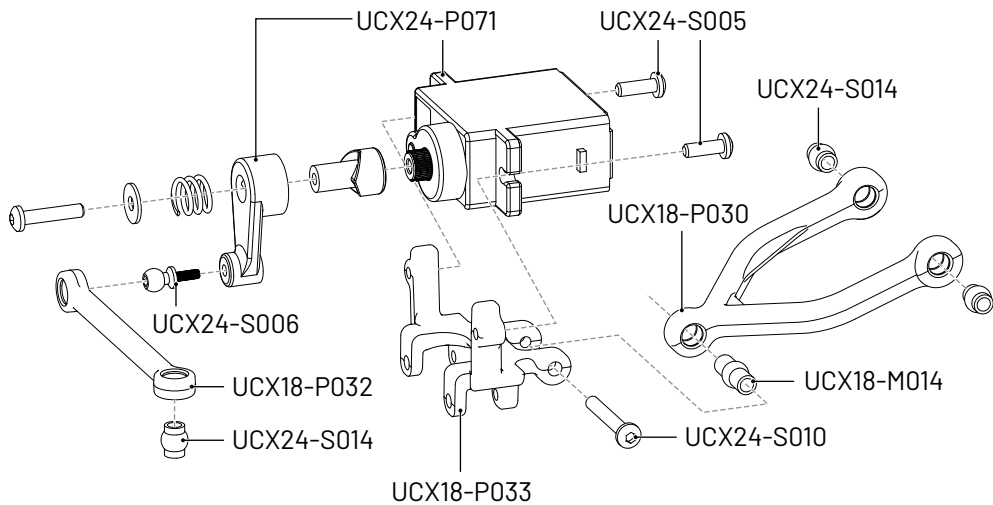

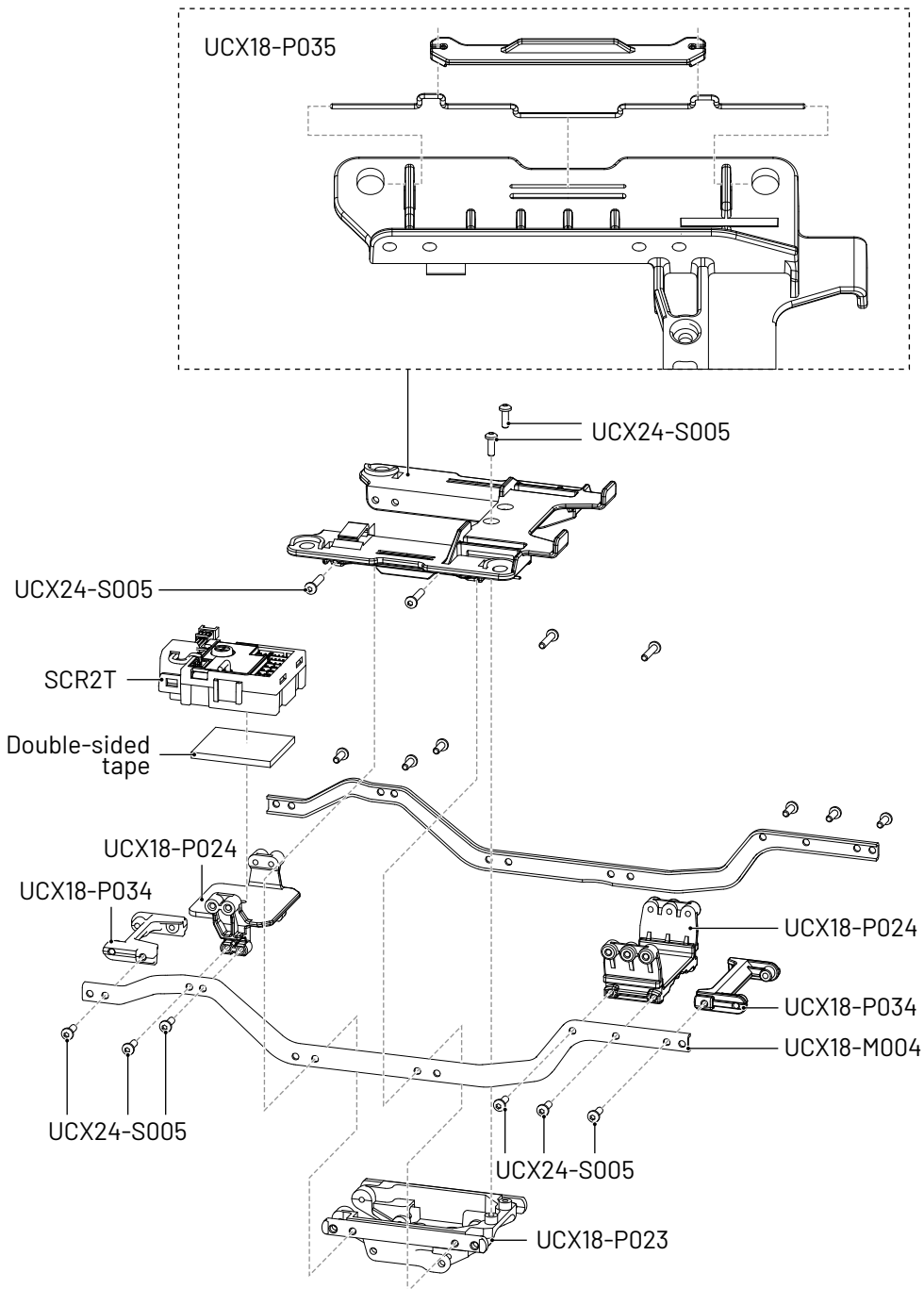

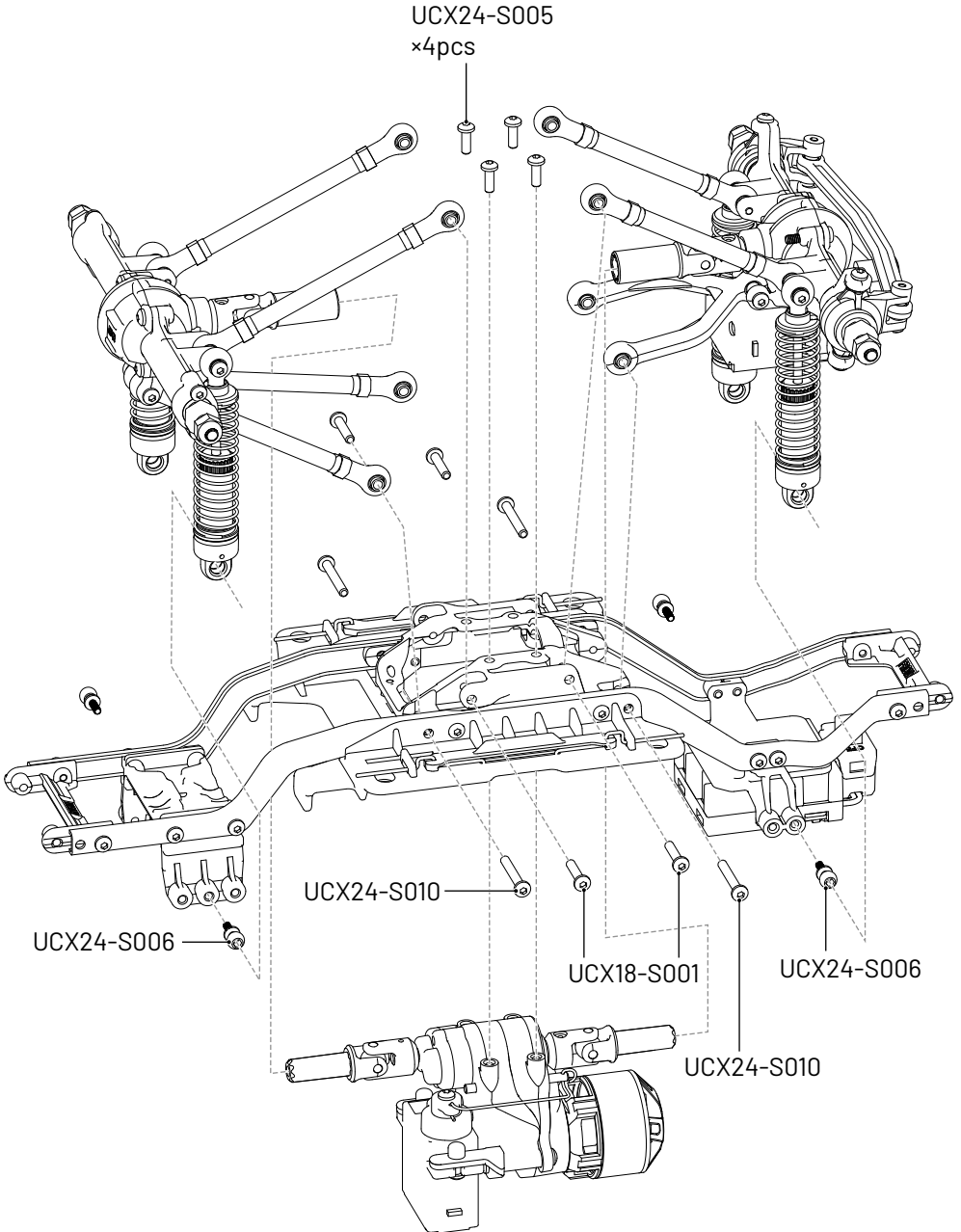



Copyright © UDIRC®, All rights reserved. Made in China
Manufacturer: SHANTOU CITY UDIRC TECHNOLOGY COMPANY LIMITED
Address: Guangfeng Industrial Zone, Guangyi street, Chenghai District,
Shantou City, Guangdong Province, China

